	<h2 style="text-align: center;">Medical University of South Carolina</h2> <p style="text-align: center;"><b>REQUEST FOR QUOTE</b></p>	Solicitation Number Date Printed Date Issued Procurement Officer Phone E-Mail Address	Q191100ADD January 3, 2019 January 3, 2019 Angie DeVeaux 843-792-2389 deveauan@musc.edu
---	---	--	--

DESCRIPTION: **Fabricate and Install Steel Beam-W8x18**  
USING GOVERNMENTAL UNIT: Medical University of South Carolina

*The Term "Offer" Means Your "Bid" or "Proposal".*

SUBMIT OFFER BY (Opening Date/Time): **January 22, 2019 @ 10:00PM(EST)** (Local) See "Deadline for Submission of Offer" provision

**QUOTATIONS MAY BE FAXED TO: 843-792-3884**

QUESTIONS MUST BE RECEIVED BY: **January 16, 2019 @ 10:00AM(EST)** See "Questions From Offeror" provision

NUMBER OF COPIES TO BE SUBMITTED: **One COPY**

SUBMIT YOUR OFFER TO THE FOLLOWING ADDRESS:

PHYSICAL ADDRESS:  
Medical University of South Carolina  
University Purchasing  
19 Hagood Avenue, Suite 408  
Charleston, SC 29425

See "Submitting Your Offer" provision

<p>CONFERENCE TYPE: <b>Site Visit(Not Mandatory)</b>  DATE &amp; TIME: <b>January 15, 2019 at 10:00am(EST)</b>  <b>Please bring your certificate of insurance.</b>  As appropriate, see "Conferences - Pre-Bid/Proposal" &amp; "Site Visit" provisions</p>	<p>LOCATION: <b>MUSC Engineering &amp; Facilities</b>  <b>2<sup>nd</sup> floor Room PG203B Small conference room</b>  <b>97 Johnathan Lucas Street Charleston, SC 29425</b></p>
--	---

<p>AWARD &amp; AMENDMENTS</p>	<p>Award will be posted at the Physical Address stated above on <b>01/22/19</b>. The award, this solicitation, and any amendments will be posted at the following web address:  <a href="https://web.musc.edu/about/leadership/institutional-offices/finance/vendor-portal/solicitations">https://web.musc.edu/about/leadership/institutional-offices/finance/vendor-portal/solicitations</a></p>
-------------------------------	---

You **must** submit a signed copy of this form with Your Offer. By submitting a bid or proposal, You agree to be bound by the terms of the Solicitation. You agree to hold Your Offer open for a minimum of thirty (30) calendar days after the Opening Date.

<p>NAME OF OFFEROR (Full legal name of business submitting the offer)</p>	<p>OFFEROR'S TYPE OF ENTITY: (Check one)</p> <p><input type="checkbox"/> Sole Proprietorship  <input type="checkbox"/> Partnership  <input type="checkbox"/> Corporation (tax-exempt)  <input type="checkbox"/> Corporate entity (not tax-exempt)  <input type="checkbox"/> Government entity (federal, state, or local)  <input type="checkbox"/> Other _____  (See "Signing Your Offer" provision.)</p>
<p>AUTHORIZED SIGNATURE  (Person signing <b>must</b> be authorized to submit binding offer to enter contract on behalf of Offeror named above.)</p>	
<p>TITLE (Business title of person signing above)</p>	
<p>PRINTED NAME (Printed name of person signing above)</p>	<p>DATE SIGNED</p>

Instructions regarding Offeror's name: Any award issued will be issued to, and the contract will be formed with, the entity identified as the offeror above. An offer may be submitted by only one legal entity. The entity named as the offeror **must** be a single and distinct legal entity. Do not use the name of a branch office or a division of a larger entity if the branch or division is not a separate legal entity, *i.e.*, a separate corporation, partnership, sole proprietorship, etc.

<p>STATE OF INCORPORATION (If offeror is a corporation, identify the state of Incorporation.)</p>	
<p>TAXPAYER IDENTIFICATION NO.  (See "Taxpayer Identification Number" provision)</p>	<p>.</p>



## Solicitation Outline

- I. Scope of Solicitation**
- II. Instructions to Offerors**
  - A. General Instructions**
  - B. Special Instructions**
- III. Scope of Work / Specifications**
- IV. Information for Offerors to Submit**
- V. Qualifications**
- VI. Award Criteria**
- VII. Terms and Conditions**
  - A. General**
  - B. Special**
- VIII. Bidding Schedule / Cost Proposal**
- IX. Attachments to Solicitation**

### **I. Scope Of Solicitation**

#### **ACQUIRE SERVICES and/or SUPPLIES/EQUIPMENT (January 2006):**

The purpose of this solicitation is to acquire services and/or supplies or equipment complying with the enclosed description and/or specifications and conditions.

[01-1005-1]

It is the intent of the Medical University of South Carolina to solicit: **Fabricate and Install Steel Beam-W8x18 Support for folding wall system per attached specification. Location for installation is in MUSC College of Health Professions Room A105**

### **II. Instructions To Offerors - A. General Instructions**

#### **DEFINITIONS, CAPITALIZATION, AND HEADINGS (FEB 2015):**

CLAUSE HEADINGS USED IN THIS SOLICITATION ARE FOR CONVENIENCE ONLY AND SHALL NOT BE USED TO CONSTRUE MEANING OR INTENT. EVEN IF NOT CAPITALIZED, THE FOLLOWING DEFINITIONS ARE APPLICABLE TO ALL PARTS OF THE SOLICITATION, UNLESS EXPRESSLY PROVIDED OTHERWISE.

AMENDMENT – means a document issued to supplement the original solicitation document.

BOARD means the South Carolina Budget & Control Board or its successor in interest. BUSINESS means any corporation, partnership, individual, sole proprietorship, joint stock company, joint venture, or any other legal entity. [11-35-310(3)]

CHANGE ORDER means any written alteration in specifications, delivery point, rate of delivery, period of performance, price, quantity, or other provisions of any contract accomplished by mutual agreement of the parties to the contract. [11-35-310(4)]

CONTRACT See clause entitled Contract Documents & Order of Precedence.

CONTRACT MODIFICATION means a written order signed by the procurement officer, directing the contractor to make changes which the clause of the contract titled “Changes,” if included herein, authorizes the Procurement Officer to order without the consent of the contractor. [11-35-310(9)]

CONTRACTOR means the Offeror receiving an award as a result of this solicitation. COVER PAGE means the top page of the original solicitation on which the solicitation is identified by number. Offerors are cautioned that Amendments may modify information provided on the Cover Page.

OFFER means the bid or proposal submitted in response this solicitation. The terms Bid and Proposal are used interchangeably with the term Offer.

OFFEROR means the single legal entity submitting the offer. The term Bidder is used interchangeably with the term Offeror.

See bidding provisions entitled Signing Your Offer and Bid/Proposal As Offer To Contract.

PAGE TWO means the second page of the original solicitation, which is labeled Page Two.

**PROCUREMENT OFFICER** means the person, or his successor, identified as such on either the Cover Page, an amendment, or an award notice.

**YOU and YOUR** means Offeror.

**SOLICITATION** means this document, including all its parts, attachments, and any Amendments.

**STATE** means the Using Governmental Unit(s) identified on the Cover Page. **SUBCONTRACTOR** means any person you contract with to perform or provide any part of the work.

**US or WE** means the using governmental unit.

**USING GOVERNMENTAL UNIT** means the unit(s) of government identified as such on the Cover Page. If the Cover Page identifies the Using Governmental Unit as "Statewide Term Contract," the phrase "Using Governmental Unit" means any South Carolina Public Procurement Unit [11-35-4610(5)] that has submitted a Purchase Order to you pursuant to the contract resulting from this solicitation. Reference the clauses titled "Purchase Orders" and "Statewide Term Contract."

**WORK** means all labor, materials, equipment, services, or property of any type, provided or to be provided by the Contractor to fulfill the Contractor's obligations under the Contract.

[02-2A003-2]

**AMENDMENTS TO SOLICITATION (JAN 2004):** (a) The Solicitation may be amended at any time prior to opening. All actual and prospective Offerors should monitor the following web site for the issuance of Amendments:

<http://academicdepartments.musc.edu/vpfa/finance/purchasingap/index.htm> Vendors Toolkit Solicitation (b) Offerors shall acknowledge receipt of any amendment to this solicitation (1) by signing and returning the amendment, (2) by identifying the amendment number and date in the space provided for this purpose on Page Two, (3) by letter, or (4) by submitting a bid that indicates in some way that the bidder received the amendment. (c) If this solicitation is amended, then all terms and conditions which are not modified remain unchanged.[02-2A005-1]

**AUTHORIZED AGENT (FEB 2015):**

All authority regarding this procurement is vested solely with the responsible Procurement Officer. Unless specifically delegated in writing, the Procurement Officer is the only government official authorized to bind the government with regard to this procurement or the resulting contract. [02-2A007-1]

**AWARD NOTIFICATION (FEB 2015)**

Notice regarding any award, cancellation of award, or extension of award will be posted at the location and on the date specified on the Cover Page or, if applicable, any notice of extension of award. Should the contract resulting from this Solicitation have a total or potential value of one hundred thousand dollars or more, such notice will be sent to all Offerors responding to the Solicitation and any award will not be effective until the eleventh day after such notice is given.

[02-2A010-2]

**BID / PROPOSAL AS OFFER TO CONTRACT (JAN 2004):**

By submitting Your Bid or Proposal, You are offering to enter into a contract with the Using Governmental Unit(s). Without further action by either party, a binding contract shall result upon final award. Any award issued will be issued to, and the contract will be formed with, the entity identified as the Offeror on the Cover Page. An Offer may be submitted by only one legal entity; "joint bids" are not allowed. [02-2A015-1]

**BID ACCEPTANCE PERIOD (JAN 2004):**

In order to withdraw Your Offer after the minimum period specified on the Cover Page, You must notify the Procurement Officer in writing. [02-2A020-1]

**BID IN ENGLISH & DOLLARS (JAN 2004):**

Offers submitted in response to this solicitation shall be in the English language and in US dollars, unless otherwise permitted by the Solicitation. [02-2A025-1]

**BOARD AS PROCUREMENT AGENT (FEB 2015)**

The Procurement Officer is an employee of the Board acting on behalf of the Using Governmental Unit(s) pursuant to the Consolidated Procurement Code. Any contracts awarded as a result of this procurement are between the Contractor and the Using Governmental Units(s). The Board is not a party to such contracts, unless and to the extent that the Board is a using governmental unit, and bears no liability for any party's losses arising out of or relating in any way to the contract.

[02-2A030-2]

**CERTIFICATE OF INDEPENDENT PRICE DETERMINATION (MAY 2008):**

GIVING FALSE, MISLEADING, OR INCOMPLETE INFORMATION ON THIS CERTIFICATION MAY RENDER YOU SUBJECT TO PROSECUTION UNDER SECTION 16-9-10 OF THE SOUTH CAROLINA CODE OF LAWS AND OTHER APPLICABLE LAWS.

(a) By submitting an offer, the offeror certifies that-

(1) The prices in this offer have been arrived at independently, without, for the purpose of restricting competition, any consultation, communication, or agreement with any other offeror or competitor relating to—

- (i) Those prices;
- (ii) The intention to submit an offer; or
- (iii) The methods or factors used to calculate the prices offered.

(2) The prices in this offer have not been and will not be knowingly disclosed by the offeror, directly or indirectly, to any other offeror or competitor before bid opening (in the case of a sealed bid solicitation) or contract award (in the case of a negotiated solicitation) unless otherwise required by law; and

(3) No attempt has been made or will be made by the offeror to induce any other concern to submit or not to submit an offer for the purpose of restricting competition.

(b) Each signature on the offer is considered to be a certification by the signatory that the signatory-

(1) Is the person in the offeror's organization responsible for determining the prices being offered in this bid or proposal, and that the signatory has not participated and will not participate in any action contrary to paragraphs (a)(1) through (a)(3) of this certification; or

(2)(i) Has been authorized, in writing, to act as agent for the offeror's principals in certifying that those principals have not participated, and will not participate in any action contrary to paragraphs (a)(1) through (a)(3) of this certification [As used in this subdivision (b)(2)(i), the term "principals" means the person(s) in the offeror's organization responsible for determining the prices offered in this bid or proposal];

(ii) As an authorized agent, does certify that the principals referenced in subdivision (b)(2)(i) of this certification have not participated, and will not participate, in any action contrary to paragraphs (a)(1) through (a)(3) of this certification; and

(iii) As an agent, has not personally participated, and will not participate, in any action contrary to paragraphs (a)(1) through (a)(3) of this certification.

(c) If the offeror deletes or modifies paragraph (a)(2) of this certification, the offeror must furnish with its offer a signed statement setting forth in detail the circumstances of the disclosure. [02-2A032-1]

#### **CERTIFICATION REGARDING DEBARMENT AND OTHER RESPONSIBILITY MATTERS (JAN 2004):**

(a)(1) By submitting an Offer, Offeror certifies, to the best of its knowledge and belief, that-

(i) Offeror and/or any of its Principals-

(A) Are not presently debarred, suspended, proposed for debarment, or declared ineligible for the award of contracts by any state or federal agency;

(B) Have not, within a three-year period preceding this offer, been convicted of or had a civil judgment rendered against them for: commission of fraud or a criminal offense in connection with obtaining, attempting to obtain, or performing a public (Federal, state, or local) contract or subcontract; violation of Federal or state antitrust statutes relating to the submission of offers; or commission of embezzlement, theft, forgery, bribery, falsification or destruction of records, making false statements, tax evasion, or receiving stolen property; and

(C) Are not presently indicted for, or otherwise criminally or civilly charged by a governmental entity with, commission of any of the offenses enumerated in paragraph (a)(1)(i)(B) of this provision.

(ii) Offeror has not, within a three-year period preceding this offer, had one or more contracts terminated for default by any public (Federal, state, or local) entity.

(2) "Principals," for the purposes of this certification, means officers; directors; owners; partners; and, persons having primary management or supervisory responsibilities within a business entity (e.g., general manager; plant manager; head of a subsidiary, division, or business segment, and similar positions).

(b) Offeror shall provide immediate written notice to the Procurement Officer if, at any time prior to contract award, Offeror learns that its certification was erroneous when submitted or has become erroneous by reason of changed circumstances.

(c) If Offeror is unable to certify the representations stated in paragraphs (a)(1), Offer must submit a written explanation regarding its inability to make the certification. The certification will be considered in connection with a review of the Offeror's

responsibility. Failure of the Offeror to furnish additional information as requested by the Procurement Officer may render the Offeror nonresponsive.

(d) Nothing contained in the foregoing shall be construed to require establishment of a system of records in order to render, in good faith, the certification required by paragraph (a) of this provision. The knowledge and information of an Offeror is not required to exceed that which is normally possessed by a prudent person in the ordinary course of business dealings.

(e) The certification in paragraph (a) of this provision is a material representation of fact upon which reliance was placed when making award. If it is later determined that the Offeror knowingly or in bad faith rendered an erroneous certification, in addition to other remedies available to the State, the Procurement Officer may terminate the contract resulting from this solicitation for default.[02-2A035-1]

**CODE OF LAWS AVAILABLE (JAN 2006):**

The South Carolina Code of Laws, including the Consolidated Procurement Code, is available at: <http://www.scstatehouse.gov/code/statmast.php> The South Carolina Regulations are available at: <http://www.scstatehouse.gov/coderegs/statmast.php> [02-2A040-2]

**DISCLOSURE OF CONFLICTS OF INTEREST OR UNFAIR COMPETITIVE ADVANTAGE (FEB 2015):**

You warrant and represent that your offer identifies and explains any unfair competitive advantage you may have in competing for the proposed contract and any actual or potential conflicts of interest that may arise from your participation in this competition or your receipt of an award. The two underlying principles are (a) preventing the existence of conflicting roles that might bias a contractor's judgment, and (b) preventing an unfair competitive advantage. If you have an unfair competitive advantage or a conflict of interest, the state may withhold award. Before withholding award on these grounds, an offeror will be notified of the concerns and provided a reasonable opportunity to respond. Efforts to avoid or mitigate such concerns, including restrictions on future activities, may be considered. Without limiting the foregoing, you represent that your offer identifies any services that relate to either this solicitation or the work and that has already been performed by you, a proposed subcontractor, or an affiliated business of either. [02-2A047-2]

**DEADLINE FOR SUBMISSION OF OFFER (JAN 2004):**

Any offer received after the Procurement Officer of the governmental body or his designee has declared that the time set for opening has arrived, shall be rejected unless the offer has been delivered to the designated purchasing office or the governmental body's mail room which services that purchasing office prior to the opening. [R.19-445.2070(G)] [02-2A050-1]

**DRUG FREE WORK PLACE CERTIFICATION (JAN 2004):**

By submitting an Offer, Contractor certifies that, if awarded a contract, Contractor will comply with all applicable provisions of The Drug-free Workplace Act, Title 44, Chapter 107 of the South Carolina Code of Laws, as amended.[02-A065-1]

**DUTY TO INQUIRE (FEB 2015):**

Offeror, by submitting an Offer, represents that it has read and understands the Solicitation and that its Offer is made in compliance with the Solicitation. Offerors are expected to examine the Solicitation thoroughly and should request an explanation of any ambiguities, discrepancies, errors, omissions, or conflicting statements in the Solicitation. Failure to do so will be at the Offeror's risk. All ambiguities, discrepancies, errors, omissions, or conflicting statements in the Solicitation shall be interpreted to require the better quality or greater quantity of work and/or materials, unless otherwise directed by amendment. Offeror assumes responsibility for any patent ambiguity in the Solicitation that Offeror does not bring to the State's attention. See clause entitled "Questions from Offerors." [02-2A070-2]

**ETHICS CERTIFICATE (MAY 2008):**

By submitting an offer, the offeror certifies that the offeror has and will comply with, and has not, and will not, induce a person to violate Title 8, Chapter 13 of the South Carolina Code of Laws, as amended (ethics act). The following statutes require special attention: Section 8-13-700, regarding use of official position for financial gain; Section 8-13-705, regarding gifts to influence action of public official; Section 8-13-720, regarding offering money for advice or assistance of public official; Sections 8-13-755 and 8-13-760, regarding restrictions on employment by former public official; Section 8-13-775, prohibiting public official with economic interests from acting on contracts; Section 8-13-790, regarding recovery of kickbacks; Section 8-13-1150, regarding statements to be filed by consultants; and Section 8-13- 1342, regarding restrictions on contributions by contractor to candidate who participated in awarding of contract. The state may rescind any contract and recover all amounts expended as a result of any action taken in violation of this provision. If contractor participates, directly or indirectly, in the evaluation or award of public contracts, including without limitation, change orders or task orders regarding a public contract, contractor shall, if required by law to file such a statement, provide the statement required by Section 8-13-1150 to the procurement officer at the same time the law requires the statement to be filed. [02-2A075-2]

**OMIT TAXES FROM PRICE (JAN 2004):** Do not include any sales or use taxes in Your price that the State may be required to pay. [02-2A080-1]

**OPEN TRADE REPRESENTATION (JUN 2015):**

By submitting an Offer, Offeror represents that Offeror is not currently engaged in the boycott of a person or an entity based in or doing business with a jurisdiction with whom South Carolina can enjoy open trade, as defined in SC Code Section 11-35-5300. [02-2A083-1]

**PROHIBITED COMMUNICATIONS AND DONATIONS (FEB 2015):**

Violation of these restrictions may result in disqualification of your offer, suspension or debarment, and may constitute a violation of law.

(a) During the period between publication of the solicitation and final award, *you must not communicate, directly or indirectly, with the Using Governmental Unit or its employees, agents or officials regarding any aspect of this procurement activity, unless otherwise approved in writing by the Procurement Officer.* All communications must be solely with the Procurement Officer. [R. 19-445.2010]

(b) You are advised to familiarize yourself with Regulation 19-445.2165, which restricts donations to a governmental entity with whom you have or seek to have a contract. *You represent that your offer discloses any gifts made, directly or through an intermediary, by you or your named subcontractors to or for the benefit of the Using Governmental Unit during the period beginning eighteen months prior to the Opening Date.* [R. 19-445.2165] [02-2A087-1]

**PUBLIC OPENING (JAN 2004):**

Offers will be publicly opened at the date/time and at the location identified on the Cover Page, or last Amendment, whichever is applicable. [02-2A090-1]

**QUESTIONS FROM OFFERORS (FEB 2015):**

(a) Any prospective offeror desiring an explanation or interpretation of the solicitation, drawings, specifications, etc., must request it in writing. Questions regarding the original solicitation or any amendment must be received by the Procurement Officer no later than five (5) days prior to opening unless an earlier date is stated on the Cover Page. Label any communication regarding your questions with the name of the procurement officer, and the solicitation's title and number. Oral explanations or instructions will not be binding. [See R. 19-445.2042(B)] Any information given a prospective offeror concerning a solicitation will be furnished promptly to all other prospective offerors as an Amendment to the solicitation, if that information is necessary for submitting offers or if the lack of it would be prejudicial to other prospective offerors. See clause entitled "Duty to Inquire." We will not identify you in our answer to your question. (b) The State seeks to permit maximum practicable competition. Offerors are urged to advise the Procurement Officer -- as soon as possible -- regarding any aspect of this procurement, including any aspect of the Solicitation that unnecessarily or inappropriately limits full and open competition. [See R. 19-445.2140] [02-2A095-2]

**All questions must be submitted in writing and received by the Procurement Officer for this solicitation no later than January 16, 2019 at 10:00 AM(EST).**

**REJECTION/CANCELLATION (JAN 2004):**

The State may cancel this solicitation in whole or in part. The State may reject any or all proposals in whole or in part. [SC Code Section 11-35-1710 & R.19-445.2065] [02-2A100-1]

**RESPONSIVENESS/IMPROPER OFFERS (JUN 2015):**

(a) Bid as Specified. Offers for supplies or services other than those specified will not be considered unless authorized by the Solicitation.

(b) Multiple Offers. Offerors may submit more than one Offer, provided that each Offer has significant differences other than price. Each separate Offer must satisfy all Solicitation requirements. If this solicitation is an Invitation for Bids, each separate offer must be submitted as a separate document. If this solicitation is a Request for Proposals, multiple offers may be submitted as one document, provided that you clearly differentiate between each offer and you submit a separate cost proposal for each offer, if applicable.

(c) Responsiveness. Any Offer which fails to conform to the material requirements of the Solicitation may be rejected as nonresponsive. Offers which impose conditions that modify material requirements of the Solicitation may be rejected. If a fixed price is required, an Offer will be rejected if the total possible cost to the State cannot be determined. Offerors will not be

given an opportunity to correct any material nonconformity. Any deficiency resulting from a minor informality may be cured or waived at the sole discretion of the Procurement Officer. [R.19-445.2070 and Section 11-35-1520(13)]

(d) Price Reasonableness: Any offer may be rejected if the Procurement Officer determines in writing that it is unreasonable as to price. [R. 19-445.2070].

(e) Unbalanced Bidding. The State may reject an Offer as nonresponsive if the prices bid are materially unbalanced between line items or subline items. A bid is materially unbalanced when it is based on prices significantly less than cost for some work and prices which are significantly overstated in relation to cost for other work, and if there is a reasonable doubt that the bid will result in the lowest overall cost to the State even though it may be the low evaluated bid, or if it is so unbalanced as to be tantamount to allowing an advance payment.

(f) **Do not submit bid samples or descriptive literature unless expressly requested.** Unsolicited bid samples or descriptive literature will not be examined or tested, will not be used to determine responsiveness, and will not be deemed to vary any of the provisions of the solicitation. S.C. Code Ann. Reg. 19-445.2077(D)[02-2A105-2]

#### **SIGNING YOUR OFFER (JAN 2004):**

Every Offer must be signed by an individual with actual authority to bind the Offeror. (a) If the Offeror is an individual, the Offer must be signed by that individual. If the Offeror is an individual doing business as a firm, the Offer must be submitted in the firm name, signed by the individual, and state that the individual is doing business as a firm. (b) If the Offeror is a partnership, the Offer must be submitted in the partnership name, followed by the words by its Partner, and signed by a general partner. (c) If the Offeror is a corporation, the Offer must be submitted in the corporate name, followed by the signature and title of the person authorized to sign.

(d) An Offer may be submitted by a joint venturer involving any combination of individuals, partnerships, or corporations. If the Offeror is a joint venture, the Offer must be submitted in the name of the Joint Venture and signed by every participant in the joint venture in the manner prescribed in paragraphs (a) through (c) above for each type of participant. (e) If an Offer is signed by an agent, other than as stated in subparagraphs (a) through (d) above, the Offer must state that it has been signed by an Agent. Upon request, Offeror must provide proof of the agent's authorization to bind the principal. [02-2A115-1]

#### **STATE OFFICE CLOSINGS (JAN 2004):**

If an emergency or unanticipated event interrupts normal government processes so that offers cannot be received at the government office designated for receipt of bids by the exact time specified in the solicitation, the time specified for receipt of offers will be deemed to be extended to the same time of day specified in the solicitation on the first work day on which normal government processes resume. In lieu of an automatic extension, an Amendment may be issued to reschedule bid opening. If state offices are closed at the time a pre-bid or pre-proposal conference is scheduled, an Amendment will be issued to reschedule the conference. Useful information may be available at: <https://scemd.org/prepare/types-of-disasters/severe-winter-weather/> [02-A120-3]

#### **SUBMITTING CONFIDENTIAL INFORMATION (FEB 2015):**

(An overview is available at [www.procurement.sc.gov](http://www.procurement.sc.gov)) For every document Offeror submits in response to or with regard to this solicitation or request, Offeror must separately mark with the word "CONFIDENTIAL" every page, or portion thereof, that Offeror contends contains information that is exempt from public disclosure because it is either (a) a trade secret as defined in Section 30-4-40(a)(1), or (b) privileged and confidential, as that phrase is used in Section 11-35-410. For every document Offeror submits in response to or with regard to this solicitation or request, Offeror must separately mark with the words "TRADE SECRET" every page, or portion thereof, that Offeror contends contains a trade secret as that term is defined by Section 39-8-20 of the Trade Secrets Act. For every document Offeror submits in response to or with regard to this solicitation or request, Offeror must separately mark with the word "PROTECTED" every page, or portion thereof, that Offeror contends is protected by Section 11-35-1810. All markings must be conspicuous; use color, bold, underlining, or some other method in order to conspicuously distinguish the mark from the other text. Do not mark your entire response (bid, proposal, quote, etc.) as confidential, trade secret, or protected. If your response, or any part thereof, is improperly marked as confidential or trade secret or protected, the State may, in its sole discretion, determine it nonresponsive. If only portions of a page are subject to some protection, do not mark the entire page. By submitting a response to this solicitation or request, Offeror (1) agrees to the public disclosure of every page of every document regarding this solicitation or request that was submitted at any time prior to entering into a contract (including, but not limited to, documents contained in a response, documents submitted to clarify a response, and documents submitted during negotiations), unless the page is conspicuously marked "TRADE SECRET" or "CONFIDENTIAL" or "PROTECTED", (2) agrees that any information not marked, as required by these bidding instructions, as a "Trade Secret" is not a trade secret as defined by the Trade Secrets Act, and (3) agrees that, notwithstanding any claims or markings otherwise, any prices, commissions, discounts, or other financial figures used to determine the award, as well as the final contract amount, are subject to public disclosure. In determining whether to release documents, the State will detrimentally rely on Offeror's marking of documents, as required by these bidding instructions, as being either "Confidential"



or "Trade Secret" or "PROTECTED". By submitting a response, Offeror agrees to defend, indemnify and hold harmless the State of South Carolina, its agencies, officers and employees, from every claim, demand, loss, expense, cost, damage or injury, including attorney's fees, arising out of or resulting from withholding information by the State of South Carolina or any of its agencies, that Offeror marked as "confidential" or "trade secret" or "PROTECTED". (All references to S.C. Code of Laws.) [02-2A125-2]

**SUBMITTING A PAPER OFFER OR MODIFICATION (MAR 2015):**

Unless specifically instructed otherwise in the solicitation, you should submit your offer or modification in accordance with the clause titled "ON-LINE BIDDING INSTRUCTIONS." Paper offers are discouraged. If you must submit a paper offer or modification the following instructions apply. (a) All prices and notations should be printed in ink or typewritten. Errors should be crossed out, corrections entered and initialed by the person signing the bid. Do not modify the solicitation document itself (including bid schedule). (b) (1) All copies of the offer or modification, and any other documents required to be submitted with the offer shall be enclosed in a sealed, opaque envelope or package.

(2) Submit your offer or modification to the address on the Cover Page. (3) The envelope or package must show the time and date specified for opening, the solicitation number, and the name and address of the bidder. If the offer or modification is sent by mail or special delivery service (UPS, Federal Express, etc.), the outermost envelope or wrapper must be labeled "OFFER ENCLOSED" on the face thereof. (c) If you are responding to more than one solicitation, submit each offer in a separate envelope or package. (d) Submit the number of copies indicated on the Cover Page.

(e) Facsimile or e-mail offers, modifications, or withdrawals, will not be considered unless authorized by the Solicitation. [02-2A130-2]

**TAX CREDIT FOR SUBCONTRACTING WITH DISADVANTAGED SMALL BUSINESSES (JAN 2008):**

Pursuant to Section 12-6-3350, a taxpayer having a contract with this State who subcontracts with a socially and economically disadvantaged small business is eligible for an income tax credit equal to four percent of the payments to that subcontractor for work pursuant to the contract. The subcontractor must be certified as a socially and economically disadvantaged small business as defined in Section 11-35-5010 and regulations pursuant to it. The credit is limited to a maximum of fifty thousand dollars annually. A taxpayer is eligible to claim the credit for ten consecutive taxable years beginning with the taxable year in which the first payment is made to the subcontractor that qualifies for the credit. After the above ten consecutive taxable years, the taxpayer is no longer eligible for the credit. A taxpayer claiming the credit shall maintain evidence of work performed for the contract by the subcontractor. The credit may be claimed on Form TC-2, "Minority Business Credit." A copy of the subcontractor's certificate from the Governor's Office of Small and Minority Business (OSMBA) is to be attached to the contractor's income tax return. Questions regarding the tax credit and how to file are to be referred to: SC Department of Revenue, Research and Review, Phone: (803) 898-5786, Fax: (803) 898-5888. Questions regarding subcontractor certification are to be referred to: Governor's Office of Small and Minority Business Assistance, Phone: (803) 734-0657, Fax: (803) 734-2498. [02-2A135-1]

**VENDOR REGISTRATION MANDATORY (JAN 2006):**

You must have a state vendor number to be eligible to submit an offer. To obtain a state vendor number, visit [www.procurement.sc.gov](http://www.procurement.sc.gov) and select New Vendor Registration. (To determine if your business is already registered, go to "Vendor Search"). Upon registration, you will be assigned a state vendor number. Vendors must keep their vendor information current. If you are already registered, you can update your information by selecting Change Vendor Registration. (Please note that vendor registration does not substitute for any obligation to register with the S.C. Secretary of State or S.C. Department of Revenue. You can register with the agencies at <http://www.scsos.com> [02-2A145-1]

**WITHDRAWAL OR CORRECTION OF OFFER (JAN 2004):**

Offers may be withdrawn by written notice received at any time before the exact time set for opening. If the Solicitation authorizes facsimile offers, offers may be withdrawn via facsimile received at any time before the exact time set for opening. A bid may be withdrawn in person by a bidder or its authorized representative if, before the exact time set for opening, the identity of the person requesting withdrawal is established and the person signs a receipt for the bid. The withdrawal and correction of Offers is governed by S.C. Code Section 11-35-1520 and Regulation 19-445.2085. [02-2A150-1]

## **II. Instructions To Offerors – B. Special Instructions**

**CLARIFICATION (NOV 2007):**

Pursuant to Section 11-35-1520(8), the Procurement Officer may elect to communicate with you after opening for the purpose of clarifying either your offer or the requirements of the solicitation. Such communications may be conducted only with offerors who have submitted an offer which obviously conforms in all material aspects to the solicitation. Clarification of an

offer must be documented in writing and included with the offer. Clarifications may not be used to revise an offeror the solicitation. [Section 11-35-1520(8); R.19-445.2080][02-2B055-1]

**PREFERENCES - A NOTICE TO VENDORS (SEP 2009):**

On June 16, 2009, the South Carolina General Assembly rewrote the law governing preferences available to in-state vendors, vendors using in-state subcontractors, and vendors selling in-state or US end products. This law appears in Section 11-35-1524 of the South Carolina Code of Laws. A summary of the new preferences is available at [www.procurement.sc.gov/preferences](http://www.procurement.sc.gov/preferences). ALL THE PREFERENCES MUST BE CLAIMED AND ARE APPLIED BY LINE ITEM, REGARDLESS OF WHETHER AWARD IS MADE BY ITEM OR LOT. VENDORS ARE CAUTIONED TO CAREFULLY REVIEW THE STATUTE BEFORE CLAIMING ANY PREFERENCES. THE REQUIREMENTS TO QUALIFY HAVE CHANGED. IF YOU REQUEST A PREFERENCE, YOU ARE CERTIFYING THAT YOUR OFFER QUALIFIES FOR THE PREFERENCE YOU'VE CLAIMED. IMPROPERLY REQUESTING A PREFERENCE CAN HAVE SERIOUS CONSEQUENCES. [11-35-1524(E)(4)&(6)] [02-2B111-1]

**PREFERENCES - SC/US END-PRODUCT (SEP 2009):**

Section 11-35-1524 provides a preference to vendors offering South Carolina end-products or US end-products, if those products are made, manufactured, or grown in SC or the US, respectively. An end-product is the tangible project identified for acquisition in this solicitation, including all component parts in final form and ready for the use intended. The terms "made," "manufactured," and "grown" are defined by Section 11-35-1524(A). By signing your offer and checking the appropriate space(s) provided and identified on the bid schedule, you certify that the end-product(s) is either made, manufactured or grown in South Carolina, or other states of the United States, as applicable. Preference will be applied as required by law. Post award substitutions are prohibited. See "Substitutions Prohibited - End Product Preferences (Sep 2009)" provision. [02-2B112-1]

**PREFERENCES - RESIDENT CONTRACTOR PREFERENCE (SEP 2009):**

To qualify for the RCP, you must maintain an office in this state. An office is a nonmobile place for the regular transaction of business or performance of a particular service which has been operated as such by the bidder for at least one year before the bid opening and during that year the place has been staffed for at least fifty weeks by at least two employees for at least thirty five hours a week each. In addition, you must, at the time you submit your bid, directly employ, or have a documented commitment with, individuals domiciled in South Carolina that will perform services expressly required by the solicitation and your total direct labor cost for those individuals to provide those services must exceed fifty percent of your total bid price. [11-35-1524(C)(1)(iii)] Upon request by the procurement officer, you must identify the persons domiciled in South Carolina that will perform the services involved in the procurement upon which you rely in qualifying for the preference, the services those individuals are to perform, and documentation of the your labor cost for each person identified. If requested, your failure to provide this information promptly will be grounds to deny the preference (and, potentially, for other enforcement action). [02-2B113A-1]

**PREFERENCES - RESIDENT CONTRACTOR PREFERENCE (SEP 2009):**

To qualify for the RCP, you must maintain an office in this state. An office is a nonmobile place for the regular transaction of business or performance of a particular service which has been operated as such by the bidder for at least one year before the bid opening and during that year the place has been staffed for at least fifty weeks by at least two employees for at least thirty five hours a week each. In addition, you must, at the time you submit your bid, directly employ, or have a documented commitment with, individuals domiciled in South Carolina that will perform services expressly required by the solicitation and your total direct labor cost for those individuals to provide those services must exceed fifty percent of your total bid price. [11-35-1524(C)(1)(iii)] Upon request by the procurement officer, you must identify the persons domiciled in South Carolina that will perform the services involved in the procurement upon which you rely in qualifying for the preference, the services those individuals are to perform, and documentation of the your labor cost for each person identified. If requested, your failure to provide this information promptly will be grounds to deny the preference (and, potentially, for other enforcement action). [02-2B113A-1]

**PREFERENCES - RESIDENT SUBCONTRACTOR PREFERENCE (SEP 2009):**

To qualify for this preference, You must meet the following requirements. (1) You must -- at the time you submit your bid -- have a documented commitment from a single proposed first tier subcontractor to perform some portion of the services expressly required by the solicitation. (2) The subcontractor -- at the time you submit your bid -- must directly employ, or have a documented commitment with, individuals domiciled in South Carolina that will perform services expressly required by the solicitation and the total direct labor cost to the subcontractor for those individuals to provide those services exceeds, as applicable, either twenty percent for a 2% preference or forty percent of bidder's total bid price for a 4% preference. (3) You must identify the subcontractor that will perform the work, the work the subcontractor is to perform, and your factual basis for

concluding that the subcontractor's work constitutes the required percentage of the work to be performed in the procurement. [11-35-1524(D)] You can stack this preference, i.e., earn another 2% or 4% preference for each additional qualifying subcontractor, but the preference is capped. [11-35-1524(D)(4), (E)(7)] Upon request by the procurement officer, you must identify the persons domiciled in South Carolina that are to perform the services involved in the procurement upon which you rely in qualifying for the preference, the services those individuals are to perform, the employer of those persons, your relationship with the employer, and documentation of the subcontractor's labor cost for each person identified. If requested, your failure to provide this information promptly will be grounds to deny the preference (and, potentially, for other enforcement action). **YOU WILL NOT RECEIVE THE PREFERENCE UNLESS YOU SPECIFY WHETHER YOU ARE CLAIMING THE 2% OR 4% PREFERENCE AND YOU PROVIDE THE INFORMATION REQUIRED BY ITEM (3) ABOVE.** [02-2B113B-1]

**PREFERENCES - RESIDENT VENDOR PREFERENCE (SEP 2009):**

To qualify for the RVP, you must maintain an office in this state. An office is a nonmobile place for the regular transaction of business or performance of a particular service which has been operated as such by the bidder for at least one year before the bid opening and during that year the place has been staffed for at least fifty weeks by at least two employees for at least thirty five hours a week each. In addition, you must either: (1) maintain at a location in South Carolina at the time of the bid an inventory of expendable items which are representative of the general type of commodities for which the award will be made and which have a minimum total value, based on the bid price, equal to the lesser of fifty thousand dollars [\$50,000] or the annual amount of the contract; or (2) be a manufacturer headquartered and having an annual payroll of at least one million dollars in South Carolina and the end product being sold is either made or processed from raw materials into a finished end product by that manufacturer or its affiliate (as defined in Section 1563 of the Internal Revenue Code). [02-2B114-1]

**SITE VISIT (JAN 2006):**

A site visit will be held at the following date, time and location. Your failure to attend will not relieve the Contractor from responsibility for estimating properly the difficulty and cost of successfully performing the work, or for proceeding to successfully perform the work without additional expense to the State. The State assumes no responsibility for any conclusions or interpretations made by the Contractor based on the information made available at the conference. Nor does the State assume responsibility for any understanding reached or representation made concerning conditions which can affect the work by any of its officers or agents before the execution of this contract, unless that understanding or representation is expressly stated in this contract.

**Date & Start Time: January 15, 2019 @ 10:00am (EST)**

**Contact Person's Name: Angie DeVeaux Contact's Phone Number: 843-792-2389**

**Location: MUSC Engineering & Facilities 2<sup>nd</sup> floor Room PG203B-Small Conference Room 97 Jonathan Lucas Street Charleston, SC 29425**

[02-2B165-1]

**UNIT PRICES REQUIRED (JAN 2006):**

Unit price to be shown for each item. [02- 2B170-1]

---

**QUOTES MAYBE:**

**EMAILED TO: [deveauan@musc.edu](mailto:deveauan@musc.edu)**

**FAX TO: 843-792-3884**

**HAND-CARRY TO:**

**Medical University of South Carolina  
19 Hagood Avenue, Suite 408  
Charleston, SC 29403**

**MAIL TO:**

**Medical University of South Carolina  
19 Hagood Avenue, Suite 408  
Charleston, SC 29425**

**PLEASE MAKE SURE THAT YOU PUT THE SOLICITATION NUMBER (Q191100ADD) ON THE OUTSIDE OF THE ENVELOPE/PACKAGE WHEN SENDING.**

**PLEASE DO NOT WAIT UNTIL THE LAST MINUTE TO SEND YOUR RESPONSE TO THE SOLICITATION.**

**QUESTIONS:**

**Please email questions to Angie DeVeaux- [deveauan@musc.edu](mailto:deveauan@musc.edu)  
Deadline for questions is January 16, 2019 @ 10:00AM(EST)**

### **III. Scope of Work / Specifications**

Fabricate and Install Steel Beam-W8x18: Support for folding wall system per attached specification. Location for installation is in MUSC College of Health Professionals Room A105

The beam and installation **shall** consist as follows:

1. Beam designed per attached drawings from RMF Engineering (separate attachment (SOOO) 1/3)
2. Installation according to attached drawings(SOOO)1/3
3. Remove ceiling necessary to accommodate steel beam
4. Owner will be responsible to remove and replace ceiling lighting
5. Some on site field welding will be needed contractor shall meet all OSHA regulation while performing this task.
6. Steel **shall** meet all seismic requirements
7. Steel beam **shall** meet required gravity load design
8. Steel beam **shall** be painted before installation
9. **All** field welds **shall** be painted
10. Contractor **shall** protect existing facilities and structure and utility system
11. Steel Beam is approximately 40ft long with associated bracing
12. Contractor to remove and replace fireproofing as needed

**REQUIREMENTS:**

- a) BID AS SPECIFIED, NO SUBSTITUTES, Prices quoted to include **all** shipping charges.
- b) **Project:** MUSC CHP A105 Structural Steel Fabrication and Installation Specification
  - i) Location: College of Health Professionals, Building A
  - ii) Address: 151A Rutledge Ave, Room A105 Charleston SC 29405
  - iii) Point of Contact Phillip Botero, 843-323-8587, [botero@musc.edu](mailto:botero@musc.edu)
- c) **Safety:**
  - i) Contractor **shall** comply with all OSHA and MUSC safety requirements.
  - ii) No welding **shall** commence without an MUSC Hot Work Permit.
  - iii) Welding requires a separate person for fire watch.
  - iv) Hot Work Permits are **only** good for day of issue and must be re-approved each day.
- d) **Workmanship:**

- i) **All** Welding, fabrication and general construction **must** be made in accordance with the latest trade's specifications. The owner reserves the right to inspection by self or other outside competent authority.
- ii) **All** personnel **shall** comply with MUSC policies on smoking, treatment of others and workplace violence.
- iii) Contractor to provide paint and skill to touchup welded surfaces as well as coatings damaged due to installation
- iv) **All** fireproofing coatings damaged during installation **shall** be replaced / repaired by the contractor
- v) **All** dimensions on the print and in the field a to be verified by the contractor
- e) **Delivery Date:** Purchase Order (JAN 2006): All work must be completed within thirty (30) working days after award.
- f) **Quality - All** items **must** be new

**g) Change Request:**

- i) **All** Change request must be made to Zone 2 Building Engineer, Phillip Botero 843-323-8587, botero@muscedu.edu.
- ii) **Only** changes with approval in writing or email **shall** be execute

**h) General Notes:**

- i) Structural drawings **shall** be used in conjunction with architectural and mechanical drawings and drawings relating to other trades. Contractor **shall** be responsible for checking and coordinating dimensions, clearances, etc. With the work of other trades. In case of conflict between drawings, the more stringent requirement **shall** govern.
- ii) In case of conflict between the drawings, notes and specifications, the specifications **shall** govern.
- iii) Work not indicated on a part of the drawings but reasonably implied to be similar to that shown at corresponding places **shall** be repeated.
- iv) Contractor **must** review **all** project documents prior to fabrication and start of construction. Report any discrepancies to Architect/Engineer prior to proceeding with work.
- v) It is the prime contractor's responsibility to protect existing facilities, structures and utility lines from **all** damage during construction.
- vi) Coordinate structural and other drawings that are part of the contract documents for anchored, embedded or supported items which may affect the structural drawings.
- vii) **All** details and sections on the drawings are intended to be typical and **shall** be construed to apply to any similar situation elsewhere on the project except where a separate detail is shown.
- viii) Use of contract drawings reproduced in whole or any part in shop drawing **shall** not relieve the contractor or subcontractors from their responsibility to accurately layout, coordinate, detail, fabricate and install a complete structure.
- ix) Contractor **must** review **all** shop drawings for conformance with the contract documents and for completeness and answer **all** contractor related questions. Stamp and initial **all** sheets prior to submitting shop drawings to or ARCHITECT/ENGINEER for review.

i) STRUCTURAL STEEL:

i) SEISMIC DESIGN VALUES: IBC-2015/ ASCE 7-10

(1)  $S_s = 1.126g$ ,  $S_d = 0.788g$

(2)  $S_1 = 0.358g$ ,  $S_{d1} = 0.402g$

(3) SITE CLASS: "D"

(4) BUILDING CATEGORY: "III"

(5) SEISMIC DESIGN CATEGORY: "D"

(6) SEISMIC FORCE RESISTING SYSTEM (EXISTING CHP BUILDING): ASCE 7-10

(7) SPECIALLY REINFORCED CONCRETE SHEAR WALLS (EXISTING, ASSUMED)

(a)  $R = 6$  (EXISTING SYSTEM, ASSUMED)

(b)  $C_d = 5$  (EXISTING SYSTEM, ASSUMED)

(c)  $I = 1.25$  (EXISTING SYSTEM, ASSUMED)

(d) TL - 8.0 (EXISTING SYSTEM, ASSUMED)

(e) Cs = .164 (EXISTING SYSTEM, ASSUMED)

(8) SEISMIC FORCE ON NONSTRUCTURAL COMPONENT (FOLDING PARTITION DOOR): ASCE 7-10 (CHAPTER 13&15)

(a) FOLDING PARTITION DOOR

(b) Rp = 2.5

(c) ap = 1.0

(d) Ip = 1.5

(e) Fp = 2.24 KIPS

ii) **All** structural steel work **shall** conform to the specifications for the design, fabrication, and erection of structural steel for buildings, current edition, of the A.I.S.C.

iii) Welds, both shop and field, **shall** conform to the American Welding Society specifications. **All** welds **shall** be done with E-70 ELECTRODES

iv) Structural steel shop drawings are required and **shall** be submitted to the Architect/Engineer for approval prior to fabrication. Shop drawings **shall not** be a reproduction of the contract documents. The general contractor **shall** review and stamp **all** shop drawings and submittals "approved" prior to submitting to architect for review.

v) Structural steel materials **shall** conform to the following ASTM specification (U.N.O.):

(1) WIDE FLANGES, STRUCTURAL TIES      ASTM A992, FY=50 KSI

(2) ANGLES, PLATES, MISC. STEEL      ASTM A36, FY=36 KSI

(3) THRD'D RODS      ASTM A36, FY=36 KSI

(4) TUBES/HSS      ASTM A500, GRADE B

(5) PIPES      ASTM A53, TYPE E OR S,

(6) ANCHOR BOLTS      ASTM A449

(7) HIGH STRENGTH BOLTS      ASTM A325 TYPE 1

vi) Provide stiffener plates on each side of web, beam or girder at points of concentrated loads. Minimum stiffener plate thickness **shall** be 1/2" or flange thickness of supporting member, whichever is greater, Unless Otherwise Noted

vii) Provide temporary bracing or guys to provide lateral support until permanent lateral bracing is installed.

viii) The prime contractor **shall** provide web reinforcement at openings in steel beams and girders for mechanical and electrical penetrations if indicated on mechanical, structural or electrical drawings. **All** openings **shall** be located at the center of the beam web depth.

ix) The prime contractor **shall** coordinate the bottom of base plate elevation with the top of concrete elevation. In case of conflict, the contractor **shall** make allowance in his bid for the more stringent requirement.

x) Cuts, holes, coping, etc. Required for work of other trades **shall** be shown on the shop drawings and made in the shop. Cuts or burning holes in structural steel members in the field will not be permitted.

xi) **All** steel details and connections **shall** be in accordance with the requirement of the American Institute of Steel Construction specifications (latest edition), including all supplements and revisions.

xii) Shop connections not specifically detailed on the drawings may be welded or bolted upon approval of the Architect/Engineer. Field connections not specifically detailed on the drawing **shall** be bolted upon approval of the ARCHITECT/ENGINEER.

xiii) Beam connections **shall** be 3/4" diameter A325 TYPE connection bolt unless otherwise noted. **All** beam and girder connections, unless shown otherwise, **shall** be at least capable of developing the uniformly distributed loading capacity of member of its span as per American Institute of Steel Construction MANUAL OF STEEL CONSTRUCTION (LATEST EDITION).

xiv) Alternate connection details may be used if such details are submitted to the ARCHITECT/ENGINEER for review and acceptance is granted. However, the ARCHITECT/ENGINEER **shall** be the sole judge of acceptability and the prime

contractor's bid **shall** anticipate the use of these specific details shown on the drawings. In any event, the contractor **shall** be responsible for the design of such alternate details which he proposes.

xv) For location of lintels, see architectural drawings. For size of lintels, see schedule. Hung lintels **shall** be provided and installed by structural steel contractor. Loose lintels **shall** be supplied and installed by miscellaneous iron and steel contractor.

xvi) Steel fabricator **shall** supply anchor bolt location drawings.

xvii) Bottoms of all columns **shall** be milled.

xviii) Fillet weld sizes not called out herein shall be 3/16" minimum.

j) FIELD WELDING:

i) **All** field welding **shall** be in accordance with AWS D1.1 STRUCTURAL WELDING CODE (LATEST EDITION)

ii) Welding **shall** be performed by qualified welders. Contractor **shall** submit welding certificates for approval.

iii) **All** welding electrodes shall be E70 with minimum yield strength of 58ksi, minimum tensile strength of 70 ksi, and minimum elongation of 22% in accordance with AWS A5.

iv) Field welding **shall** be shown on erection drawings.

v) Repair **all** damaged primer at adjacent areas after weld inspection is complete.

vi) Minimum weld for framing and miscellaneous steel **shall** be 3/16" fillet weld **all** around unless noted otherwise.

vii) All weld filler metal **shall** have a minimum CVN toughness of 20 ft-lbs at minus 10 degrees Fahrenheit and 40 ft-lb at 70° Fahrenheit.

viii) The prime contractor **shall** schedule weld testing and inspection such that reports may be reviewed by the Architect/Engineer and approval or recommendation for further testing or remedial action may be made while welds are still accessible.

ix) Subcontractor **shall** submit detail weld procedure for each type of weld to be completed. Information **shall** be made available to the weld inspector.

x) Testing and inspection of field welds **shall** be conducted by an independent testing agency (commissioned by the owner) in accordance with the schedule of special inspections.

#### **DELIVERY / PERFORMANCE LOCATION - PURCHASE ORDER (JAN 2006):**

After award, all deliveries shall be made and all services provided to the location specified by the Using Governmental Unit in its purchase order. [03-3015-1]

#### **INSTALLATION (JAN 2006):**

Contractor shall install all items acquired pursuant to this contract as follows: to the specifications [3-3050-1]

#### **QUALITY – NEW (JAN 2006):**

All items must be new. [03-3060-1]

### **IV. Information For Offerors To Submit**

IN ACCORDANCE WITH SOLICITATION SECTION II.A., VENDOR REGISTRATION MANATORY (JAN 2006) - YOU MUST HAVE A STATE VENDOR NUMBER TO BE ELIGIBLE TO SUBMIT AN OFFER.

PLEASE SUBMIT STATE VENDOR NUMBER: \_\_\_\_\_

**INFORMATION FOR OFFERORS TO SUBMIT - EVALUATION (JAN 2006):**

In addition to information requested elsewhere in this solicitation, offerors should submit the following information for purposes of evaluation: All information should be presented in the listed order [04-4005-1]

**INFORMATION FOR OFFERORS TO SUBMIT – GENERAL (MAR 2015):**

You shall submit a signed Cover Page and Page Two. **If you submit your offer electronically, you must upload an image of a signed Cover Page and Page Two.** Your offer should include all other information and documents requested in this part and in parts II.B. Special Instructions; III. Scope of Work; V. Qualifications; VIII. Bidding Schedule/Price Proposal; and any appropriate attachments addressed in Part IX. Attachments to Solicitations. You should submit a summary of all insurance policies you have or plan to acquire to comply with the insurance requirements stated herein, if any, including policy types; coverage types; limits, sub-limits, and deductibles for each policy and coverage type; the carrier’s A.M. Best rating; and whether the policy is written on an occurrence or claims-made basis. [04-4010-2]

**MINORITY PARTICIPATION (JANUARY 2006):**

- Is the bidder a South Carolina Certified Minority Business?  Yes  NO
- Is the bidder a Minority Business certified by another governmental entity?  Yes  NO
- If so, please list the certifying governmental entity: \_\_\_\_\_
- Will any of the work under this contract be performed by a SC certified Minority Business as a subcontractor?  Yes  NO
- If so, what percentage of the total value of the contract will be performed by a SC certified Minority Business as a subcontractor?  Yes  NO
- Will any of the work under this contract be performed by a minority business certified by another governmental entity as a subcontractor?  Yes  NO
- If so, what percentage of the total value of the contract will be performed by a minority business certified by another governmental entity as a subcontractor?  Yes  NO
- If a certified Minority Business is participating in this contract, please indicate all categories for which the Business is certified:
- Traditional minority
- Traditional minority, but female
- Women (Caucasian females)
- Hispanic minorities
- DOT referral (Traditional minority)
- DOT referral (Caucasian female)
- Temporary certification
- SBA 8 (a) certification referral
- Other minorities (Native American, Asian, etc.)

(If more than one minority contractor will be utilized in the performance of this contract, please provide the information above for each minority business.)

For a list of certified minority firms, please consult the Minority Business Directory, which is available at the following URL: <http://osmba.sc.gov/directory.html> [04-4015-1]

**RECYCLED PRODUCT (JAN 2006):**

Offeror shall identify which product(s) is made out of or contains recycled materials. This information will be used for future research  Yes  No (Items: ) If the above applies to more than one item, please indicate above. [04-4025-1]

**V. Qualifications**

**QUALIFICATION OF OFFEROR (MAR 2015):**

(1) To be eligible for award, you must have the capability in all respects to perform fully the contract requirements and the integrity and reliability which will assure good faith performance. We may also consider a documented commitment from a satisfactory source that will provide you with a capability. We may consider information from any source at any time prior to award. We may elect to consider (i) key personnel, any predecessor business, and anykey personnel of any predecessor



business, including any facts arising prior to the date a business was established, and/or (ii) any subcontractor you identify. (2) You must promptly furnish satisfactory evidence of responsibility upon request. Unreasonable failure to supply requested information is grounds for rejection. (3) **Corporate subsidiaries are cautioned that the financial capability of an affiliated or parent company will not be considered in determining financial capability**; however, we may elect to consider any security, e.g., letter of credit, performance bond, parent- company corporate guaranty, that you offer to provide Instructions and forms to help assure acceptability are posted on procurement.sc.gov, link to “Standard Clauses & Provisions.” [05-5005-2]

#### **QUALIFICATIONS – REQUIRED INFORMATION (MAR 2015):**

Submit the following information or documentation for you and for any subcontractor (at any tier level) that you identify pursuant to the clause titled Subcontractor – Identification. Err on the side of inclusion. You represent that the information provided is complete. (a) The general history and experience of the business in providing work of similar size and scope. (b) Information reflecting the current financial position. Include the most current financial statement and financial statements for the last two fiscal years. If the financial statements have been audited in accordance with the following requirements, provide the audited version of those statements. [Reference Statement of Financial Accounting Concepts No. 5 (FASB, December, 1984), as amended.] (c) A detailed, narrative statement listing the three most recent, comparable contracts (including contact information) which have been performed. For each contract, describe how the supplies or services provided are similar to those requested by this solicitation, and how they differ. (d) A list of every business for which supplies or services substantially similar to those sought with this solicitation have been provided, at any time during the past three years. (e) A list of every South Carolina public body for which supplies or services have been provided at any time during the past three years, if any. (f) List of failed projects, suspensions, debarments, and significant litigation. [05-5015-2]

#### **SUBCONTRACTOR – IDENTIFICATION (FEB 2015):**

If you intend to subcontract, at any tier level, with another business for any portion of the work and that portion either (1) exceeds 10% of your cost, (2) involves access to any “government information,” as defined in the clause entitled “Information Security - Definitions,” if included, or (3) otherwise involves services critical to your performance of the work (err on the side of inclusion), your offer must identify that business and the work which they are to perform. Identify potential subcontractors by providing the business name, address, phone, taxpayer identification number, and point of contact. In determining your responsibility, the state may contact and evaluate your proposed subcontractors. [05- 5030-2]

## **VI. Award Criteria**

#### **AWARD CRITERIA – BIDS (JAN 2006):**

Award will be made to the lowest responsible and responsive bidder(s). [06-6020-1]

#### **AWARD TO ONE OFFEROR (JAN 2006):**

Award will be made to one Offeror. [06-6049-1]

#### **CALCULATING THE LOW BID (MODIFIED)**

In calculating the Low Bid, all pricing will be taken from Bidding Schedule.

An award will be made to the responsive and responsible bidder that offers the lowest Total Evaluated Amount.

Failure to offer on all Line Items will result in rejection of the offer.

#### **UNIT PRICE GOVERNS (JAN 2006):**

In determining award, unit prices will govern over extended prices unless otherwise stated. [06-6075-1]

## **VII. Terms and Conditions – A. General**

### **ASSIGNMENT, NOVATION, AND CHANGE OF NAME, IDENTITY, OR STRUCTURE (FEB 2015):**

(a) Contractor shall not assign this contract, or its rights, obligations, or any other interest arising from this contract, or delegate any of its performance obligations, without the express written consent of the responsible procurement officer. The foregoing restriction does not apply to a transfer that occurs by operation of law (e.g., bankruptcy; corporate reorganizations and consolidations, but not including partial asset sales). Notwithstanding the foregoing, contractor may assign monies receivable under the contract provided that the state shall have no obligation to make payment to an assignee until thirty days after contractor (not the assignee) has provided the responsible procurement officer with (i) proof of the assignment, (ii) the identity (by contract number) of the specific state contract to which the assignment applies, and (iii) the name of the assignee and the exact address or account information to which assigned payments should be made. (b) If contractor amends, modifies, or otherwise changes its name, its identity (including its trade name), or its corporate, partnership or other structure, or its FEIN, contractor shall provide the procurement officer prompt written notice of such change. (c) Any name change, transfer, assignment, or novation is subject to the conditions and approval required by Regulation 19-445.2180, which does not restrict transfers by operation of law. [07-7A004-2]

### **BANKRUPTCY - GENERAL (FEB 2015):**

(a) Notice. In the event the Contractor enters into proceedings relating to bankruptcy, whether voluntary or involuntary, the Contractor agrees to furnish written notification of the bankruptcy to the Using Governmental Unit. This notification shall be furnished within two (2) days of the initiation of the proceedings relating to the bankruptcy filing. This notification shall include the date on which the bankruptcy petition was filed, the identity of the court in which the bankruptcy petition was filed, and a listing of all State contracts against which final payment has not been made. This obligation remains in effect until final payment under this Contract. (b) Termination. This contract is voidable and subject to immediate termination by the State upon the contractor's insolvency, including the filing of proceedings in bankruptcy. [07-7A005-2]

### **CHOICE-OF-LAW (JAN 2006):**

The Agreement, any dispute, claim, or controversy relating to the Agreement, and all the rights and obligations of the parties shall, in all respects, be interpreted, construed, enforced and governed by and under the laws of the State of South Carolina, except its choice of law rules. As used in this paragraph, the term "Agreement" means any transaction or agreement arising out of, relating to, or contemplated by the solicitation. [07-7A010-1]

### **CONTRACT DOCUMENTS & ORDER OF PRECEDENCE (FEB 2015):**

(a) Any contract resulting from this solicitation shall consist of the following documents:  
(1) a Record of Negotiations, if any, executed by you and the Procurement Officer, (2) the solicitation, as amended, (3) documentation of clarifications [11-35-1520(8)] or discussions [11-35-1530(6)] of an offer, if applicable, (4) your offer, (5) any statement reflecting the state's final acceptance (a/k/a "award"), and (6) purchase orders. These documents shall be read to be consistent and complementary. Any conflict among these documents shall be resolved by giving priority to these documents in the order listed above.  
(b) The terms and conditions of documents (1) through (5) above shall apply notwithstanding any additional or different terms and conditions in any other document, including without limitation, (i) a purchase order or other instrument submitted by the State, (ii) any invoice or other document submitted by Contractor, or (iii) any privacy policy, terms of use, or end user agreement. Except as otherwise allowed herein, the terms and conditions of all such documents shall be void and of no effect.  
(c) No contract, license, or other agreement containing contractual terms and conditions will be signed by any Using Governmental Unit. Any document signed or otherwise agreed to by persons other than the Procurement Officer shall be void and of no effect. [07-7A015-2]

### **DISCOUNT FOR PROMPT PAYMENT (JAN 2006):**

(a) Discounts for prompt payment will not be considered in the evaluation of offers. However, any offered discount will form a part of the award, and will be taken if payment is made within the discount period indicated in the offer by the offeror. As an alternative to offering a discount for prompt payment in conjunction with the offer, offerors awarded contracts may include discounts for prompt payment on individual invoices.  
(b) In connection with any discount offered for prompt payment, time shall be computed from the date of the invoice. If the Contractor has not placed a date on the invoice, the due date shall be calculated from the date the designated billing office receives a proper invoice, provided the state annotates such invoice with the date of receipt at the time of receipt. For the purpose of computing the discount earned, payment shall be considered to have been made on the date that appears on the

payment check or, for an electronic funds transfer, the specified payment date. When the discount date falls on a Saturday, Sunday, or legal holiday when Federal Government offices are closed and Government business is not expected to be conducted, payment may be made on the following business day. [07-7A020-1]

**DISPUTES (JAN 2006):**

(1) Choice-of-Forum. All disputes, claims, or controversies relating to the Agreement shall be resolved exclusively by the appropriate Chief Procurement Officer in accordance with Title 11, Chapter 35, Article 17 of the South Carolina Code of Laws, or in the absence of jurisdiction, only in the Court of Common Pleas for, or a federal court located in, Richland County, State of South Carolina.

Contractor agrees that any act by the Government regarding the Agreement is not a waiver of either the Government's sovereign immunity or the Government's immunity under the Eleventh Amendment of the United States Constitution. As used in this paragraph, the term "Agreement" means any transaction or agreement arising out of, relating to, or contemplated by the solicitation. (2) Service of Process. Contractor consents that any papers, notices, or process necessary or proper for the initiation or continuation of any disputes, claims, or controversies relating to the Agreement; for any court action in connection therewith; or for the entry of judgment on any award made, may be served on Contractor by certified mail (return receipt requested) addressed to Contractor at the address provided as the Notice Address on Page Two or by personal service or by any other manner that is permitted by law, in or outside South Carolina.

Notice by certified mail is deemed duly given upon deposit in the United States mail. [07-7A025-1]

**EQUAL OPPORTUNITY (JAN 2006):**

Contractor is referred to and shall comply with all applicable provisions, if any, of Title 41, Part 60 of the Code of Federal Regulations, including but not limited to Sections 60-1.4, 60-4.2, 60-4.3, 60-250.5(a), and 60- 741.5(a), which are hereby incorporated by reference. [07-7A030-1]

**FALSE CLAIMS (JAN 2006):**

According to the S.C. Code of Laws Section 16-13-240, "a person who by false pretense or representation obtains the signature of a person to a written instrument or obtains from another person any chattel, money, valuable security, or other property, real or personal, with intent to cheat and defraud a person of that property is guilty" of a crime. [07-7A035-1]

**FIXED PRICING REQUIRED (JAN 2006):**

Any pricing provided by contractor shall include all costs for performing the work associated with that price. Except as otherwise provided in this solicitation, contractor's price shall be fixed for the duration of this contract, including option terms. This clause does not prohibit contractor from offering lower pricing after award. [07-7A040-1]

**NO INDEMNITY OR DEFENSE (FEB 2015):**

Any term or condition is void to the extent it requires the State to indemnify, defend, or pay attorney's fees to anyone for any reason. [07-7A045-2]

**NOTICE (JAN 2006):**

(A) After award, any notices shall be in writing and shall be deemed duly given (1) upon actual delivery, if delivery is by hand, (2) upon receipt by the transmitting party of automated confirmation or answer back from the recipient's device if delivery is by telex, telegram, facsimile, or electronic mail, or (3) upon deposit into the United States mail, if postage is prepaid, a return receipt is requested, and either registered or certified mail is used. (B) Notice to contractor shall be to the address identified as the Notice Address on Page Two. Notice to the state shall be to the Procurement Officer's address on the Cover Page. Either party may designate a different address for notice by giving notice in accordance with this paragraph. [07- 7A050-1]

**OPEN TRADE (JUN 2015):**

During the contract term, including any renewals or extensions, Contractor will not engage in the boycott of a person or an entity based in or doing business with a jurisdiction with whom South Carolina can enjoy open trade, as defined in SC Code Section 11-35-5300. [07-7A053-1]

**PAYMENT & INTEREST (FEB 2015):**

(a) The State shall pay the Contractor, after the submission of proper invoices or vouchers, the prices stipulated in this contract for supplies delivered and accepted or services rendered and accepted, less any deductions provided in this contract. Unless otherwise specified herein, including the purchase order, payment shall not be made on partial deliveries accepted by the Government. (b) Unless otherwise provided herein, including the purchase order, payment will be made by check mailed to the payment address on "Page Two." (c) Notwithstanding any other provision, payment shall be made in accordance with S.C. Code Section 11-35-45, or Chapter 6 of Title 29 (real property improvements) when applicable, which provides the Contractor's exclusive means of recovering any type of interest from the Owner. Contractor waives imposition of an interest penalty unless the invoice submitted specifies that the late penalty is applicable. Except as set forth in this paragraph, the State shall not be liable for the payment of interest on any debt or claim arising out of or related to this contract for any reason. (d) Amounts due to the State shall bear interest at the rate of interest established by the South Carolina Comptroller General pursuant to Section 11-35-45 ("an amount not to exceed fifteen percent each year"), as amended, unless otherwise required by Section 29-6-30. (e) Any other basis for interest, including but not limited to general (pre- and post-judgment) or specific interest statutes, including S.C. Code Ann. Section 34-31-20, are expressly waived by both parties. If a court, despite this agreement and waiver, requires that interest be paid on any debt by either party other than as provided by items (c) and (d) above, the parties further agree that the applicable interest rate for any given calendar year shall be the lowest prime rate as listed in the first edition of the Wall Street Journal published for each year, applied as simple interest without compounding. (f) The State shall have all of its common law, equitable and statutory rights of set-off. [07-7A055-3]

**PUBLICITY (JAN 2006):**

Contractor shall not publish any comments or quotes by State employees, or include the State in either news releases or a published list of customers, without the prior written approval of the Procurement Officer. [07-7A060-1]

**PURCHASE ORDERS (JAN 2006):**

Contractor shall not perform any work prior to the receipt of a purchase order from the using governmental unit. The using governmental unit shall order any supplies or services to be furnished under this contract by issuing a purchase order. Purchase orders may be used to elect any options available under this contract, e.g., quantity, item, delivery date, payment method, but are subject to all terms and conditions of this contract. Purchase orders may be electronic. No particular form is required. An order placed pursuant to the purchasing card provision qualifies as a purchase order. [07-7A065-1]

**SURVIVAL OF OBLIGATIONS (JAN 2006):**

The Parties' rights and obligations which, by their nature, would continue beyond the termination, cancellation, rejection, or expiration of this contract shall survive such termination, cancellation, rejection, or expiration, including, but not limited to, the rights and obligations created by the following clauses: Indemnification - Third Party Claims, Intellectual Property Indemnification, and any provisions regarding warranty or audit. [07-7A075-1]

**TAXES (JAN 2006):**

Any tax the contractor may be required to collect or pay upon the sale, use or delivery of the products shall be paid by the State, and such sums shall be due and payable to the contractor upon acceptance. Any personal property taxes levied after delivery shall be paid by the State. It shall be solely the State's obligation, after payment to contractor, to challenge the applicability of any tax by negotiation with, or action against, the taxing authority. Contractor agrees to refund any tax collected, which is subsequently determined not to be proper and for which a refund has been paid to contractor by the taxing authority. In the event that the contractor fails to pay, or delays in paying, to any taxing authorities, sums paid by the State to contractor, contractor shall be liable to the State for any loss (such as the assessment of additional interest) caused by virtue of this failure or delay. Taxes based on Contractor's net income or assets shall be the sole responsibility of the contractor. [07-7A080-1]

**TERMINATION DUE TO UNAVAILABILITY OF FUNDS (JAN 2006):**

Payment and performance obligations for succeeding fiscal periods shall be subject to the availability and appropriation of funds therefor. When funds are not appropriated or otherwise made available to support continuation of performance in a subsequent fiscal period, the contract shall be canceled. In the event of a cancellation pursuant to this paragraph, contractor will be reimbursed the resulting unamortized, reasonably incurred, nonrecurring costs. Contractor will not be reimbursed any costs amortized beyond the initial contract term. [07-7A085-1]

**THIRD PARTY BENEFICIARY (JAN 2006):**

This Contract is made solely and specifically among and for the benefit of the parties hereto, and their respective successors and assigns, and no other person will have any rights, interest, or claims hereunder or be entitled to any benefits under or on account of this Contract as a third party beneficiary or otherwise. [07-7A090-1]

**WAIVER (JAN 2006):**

The State does not waive any prior or subsequent breach of the terms of the Contract by making payments on the Contract, by failing to terminate the Contract for lack of performance, or by failing to strictly or promptly insist upon any term of the Contract. Only the Procurement Officer has actual authority to waive any of the State’s rights under this Contract. Any waiver must be in writing.  
[07-7A095-1]

**VII. Terms and Conditions – B. Special**

**CHANGES (JAN 2006):**

(1) Contract Modification. By a written order, at any time, and without notice to any surety, the Procurement Officer may, subject to all appropriate adjustments, make changes within the general scope of this contract in any one or more of the following:

- (a) drawings, designs, or specifications, if the supplies to be furnished are to be specially manufactured for the [State] in accordance therewith;
- (b) method of shipment or packing;
- (c) place of delivery;
- (d) description of services to be performed;
- (e) time of performance (i.e., hours of the day, days of the week, etc.); or,
- (f) place of performance of the services. Subparagraphs (a) to (c) apply only if supplies are furnished under this contract. Subparagraphs (d) to (f) apply only if services are performed under this contract.

(2) Adjustments of Price or Time for Performance. If any such change increases or decreases the contractor’s cost of, or the time required for, performance of any part of the work under this contract, whether or not changed by the order, an adjustment shall be made in the contract price, the delivery schedule, or both, and the contract modified in writing accordingly. Any adjustment in contract price made pursuant to this clause shall be determined in accordance with the Price Adjustment Clause of this contract. Failure of the parties to agree to an adjustment shall not excuse the contractor from proceeding with the contract as changed, provided that the State promptly and duly make such provisional adjustments in payment or time for performance as may be reasonable. By proceeding with the work, the contractor shall not be deemed to have prejudiced any claim for additional compensation, or an extension of time for completion.

(3) Time Period for Claim. Within 30 days after receipt of a written contract modification under Paragraph (1) of this clause, unless such period is extended by the Procurement Officer in writing, the contractor shall file notice of intent to assert a claim for an adjustment. Later notification shall not bar the contractor’s claim unless the State is prejudiced by the delay in notification.

(4) Claim Barred After Final Payment. No claim by the contractor for an adjustment hereunder shall be allowed if notice is not given prior to final payment under this contract. [07-7B025-1]

**COMPLIANCE WITH LAWS (JAN 2006):**

During the term of the contract, contractor shall comply with all applicable provisions of laws, codes, ordinances, rules, regulations, and tariffs. [07-7B035-1]

**CONTRACTOR’S LIABILITY INSURANCE - GENERAL (FEB 2015):**

(a) Without limiting any of the obligations or liabilities of Contractor, Contractor shall procure from a company or companies lawfully authorized to do business in South Carolina and with a current A.M. Best rating of no less than A: VII, and maintain for the duration of the contract, insurance against claims for injuries to persons or damages to property which may arise from or in connection with the performance of the work and the results of that work by the contractor, his agents, representatives, employees or subcontractors.

(b) Coverage shall be at least as broad as:

(1) Commercial General Liability (CGL): Insurance Services Office (ISO) Form CG 00 01 12 07 covering CGL on an “occurrence” basis, including products-completed operations, personal and advertising injury, with limits no less than

\$1,000,000 per occurrence. If a general aggregate limit applies, the general aggregate limit shall be twice the required occurrence limit. This contract shall be considered to be an “insured contract” as defined in the policy.

(2) Auto Liability: ISO Form Number CA 00 01 covering any auto (Code 1), or if Contractor has no owned autos, hired, (Code 8) and non-owned autos (Code 9), with limits no less than \$1,000,000 per accident for bodily injury and property damage.

(3) Worker’s Compensation: As required by the State of South Carolina, with Statutory Limits, and Employer’s Liability Insurance with limit of no less than \$1,000,000 per accident for bodily injury or disease.

(c) Every applicable Using Governmental Unit, and the officers, officials, employees and volunteers of any of them, must be covered as additional insureds on the CGL policy with respect to liability arising out of work or operations performed by or on behalf of the Contractor including materials, parts or equipment furnished in connection with such work or operations. General liability coverage can be provided in the form of an endorsement to the Contractor’s insurance at least as broad as ISO Form CG 20 10 11 85 or if not available, through the addition of both CG 20 10 and CG 20 37 if a later edition is used.

(d) For any claims related to this contract, the Contractor’s insurance coverage shall be primary insurance as respects the State, every applicable Using Governmental Unit, and the officers, officials, employees and volunteers of any of them. Any insurance or self-insurance maintained by the State, every applicable Using Governmental Unit, or the officers, officials, employees and volunteers of any of them, shall be excess of the Contractor’s insurance and shall not contribute with it.

(e) Prior to commencement of the work, the Contractor shall furnish the State with original certificates and amendatory endorsements or copies of the applicable policy language effecting coverage required by this section. All certificates are to be received and approved by the State before work commences. However, failure to obtain the required documents prior to the work beginning shall not waive the Contractor’s obligation to provide them. The State reserves the right to require complete, certified copies of all required insurance policies, including endorsements required by this section, at any time.

(f) Should any of the above described policies be cancelled before the expiration date thereof, notice will be delivered in accordance with the policy provisions. In addition, the Contractor shall notify the State immediately upon receiving any information that any of the coverages required by this section are or will be changed, cancelled, or replaced.

(g) Contractor hereby grants to the State and every applicable Using Governmental Unit a waiver of any right to subrogation which any insurer of said Contractor may acquire against the State or applicable Using Governmental Unit by virtue of the payment of any loss under such insurance. Contractor agrees to obtain any endorsement that may be necessary to effect this waiver of subrogation, but this provision applies regardless of whether or not the State or Using Governmental Unit has received a waiver of subrogation endorsement from the insurer.

(h) Any deductibles or self-insured retentions must be declared to and approved by the State. The State may require the Contractor to purchase coverage with a lower deductible or retention or provide proof of ability to pay losses and related investigations, claim administration, and defense expenses within the retention.

(i) The State reserves the right to modify these requirements, including limits, based on the nature of the risk, prior experience, insurer, coverage, or other special circumstances. [07-7B056-2]

**CONTRACTOR PERSONNEL (JAN 2006):**

The Contractor shall enforce strict discipline and good order among the Contractor’s employees and other persons carrying out the Contract. The Contractor shall not permit employment of unfit persons or persons not skilled in tasks assigned to them. [07-7B060-1]

**CONTRACTOR’S OBLIGATION – GENERAL (JAN 2006):**

The contractor shall provide and pay for all materials, tools, equipment, labor and professional and non-professional services, and shall perform all other acts and supply all other things necessary, to fully and properly perform and complete the work. The contractor must act as the prime contractor and assume full responsibility for any subcontractor’s performance. The contractor will be considered the sole point of contact with regard to all situations, including payment of all charges and the meeting of all other requirements. [07-7B065- 1]

**CONTRACTOR’S USE OF STATE PROPERTY (JAN 2006):**

Upon termination of the contract for any reason, the State shall have the right, upon demand, to obtain access to, and possession of, all State properties, including, but not limited to, current copies of all State application programs and necessary documentation, all data, files, intermediate materials and supplies held by the contractor. Contractor shall not use, reproduce, distribute, display, or sell any data, material, or documentation owned exclusively by the State without the State’s written consent, except to the extent necessary to carry out the work. [07-7B067-1]

**DEFAULT – SHORT FORM (FEB 2015):**

The state may terminate this contract, or any part hereof, for cause in the event of any default by the contractor, or if the contractor fails to comply with any material contract terms and conditions, or fails to provide the state, upon request, with

adequate assurances of future performance. In the event of termination for cause, the state shall not be liable to the contractor for any amount for supplies or services not accepted, and the contractor shall be liable to the state for any and all rights and remedies provided by law. If it is determined that the state improperly terminated this contract for default, such termination shall be deemed a termination for convenience. [07-7B080-2]

#### **DISPOSAL OF PACKAGING (JAN 2006):**

Contractor shall dispose of all wrappings, crating, and other disposable materials pertaining to this contract at the end of each working day and upon completion of installation. [07-7B085-1]

#### **ILLEGAL IMMIGRATION (NOV 2008):**

(An overview is available at [www.procurement.sc.gov](http://www.procurement.sc.gov) ) By signing your offer, you certify that you will comply with the applicable requirements of Title 8, Chapter 14 of the South Carolina Code of Laws and agree to provide to the State upon request any documentation required to establish either: (a) that Title 8, Chapter 14 is inapplicable to you and your subcontractors or sub-subcontractors; or (b) that you and your subcontractors or sub-subcontractors are in compliance with Title 8, Chapter 14. Pursuant to Section 8-14-60, "A person who knowingly makes or files any false, fictitious, or fraudulent document, statement, or report pursuant to this chapter is guilty of a felony, and, upon conviction, must be fined within the discretion of the court or imprisoned for not more than five years, or both." You agree to include in any contracts with your subcontractors language requiring your subcontractors to (a) comply with the applicable requirements of Title 8, Chapter 14, and (b) include in their contracts with the sub-subcontractors language requiring the sub-subcontractors to comply with the applicable requirements of Title 8, Chapter 14. [07-7B097-1]

#### **INDEMNIFICATION-THIRD PARTY CLAIMS – GENERAL (NOV 2011):**

Notwithstanding any limitation in this agreement, and to the fullest extent permitted by law, Contractor shall defend and hold harmless Indemnitees for and against any and all suits or claims of any character (and all related damages, settlement payments, attorneys' fees, costs, expenses, losses or liabilities) by a third party which are attributable to bodily injury, sickness, disease or death, or to injury to or destruction of tangible property arising out of or in connection with the goods or services acquired hereunder or caused in whole or in part by any act or omission of contractor, its subcontractors, their employees, workmen, servants, agents, or anyone directly or indirectly employed by them or anyone for whose acts any of them may be liable, regardless of whether or not caused in part by an Indemnitee, and whether or not such claims are made by a third party or an Indemnitee; however, if an Indemnitee's negligent act or omission is subsequently determined to be the sole proximate cause of a suit or claim, the Indemnitee shall not be entitled to indemnification hereunder.

Contractor shall be given timely written notice of any suit or claim. Contractor's obligations hereunder are in no way limited by any protection afforded under workers' compensation acts, disability benefits acts, or other employee benefit acts. This clause shall not negate, abridge, or reduce any other rights or obligations of indemnity which would otherwise exist. The obligations of this paragraph shall survive termination, cancelation, or expiration of the parties' agreement. This provision shall be construed fairly and reasonably, neither strongly for nor against either party, and without regard to any clause regarding insurance. As used in this clause, "Indemnitees" means the State of South Carolina, its instrumentalities, agencies, departments, boards, political subdivisions and all their respective officers, agents and employees. [07-7B100-2]

#### **INDEMNIFICATION - INTELLECTUAL PROPERTY (JAN 2006):**

(a) Without limitation and notwithstanding any provision in this agreement, Contractor shall, upon receipt of notification, defend and indemnify the State, its instrumentalities, agencies, departments, boards, political subdivisions and all their respective officers, agents and employees against all actions, proceedings or claims of any nature (and all damages, settlement payments, attorneys' fees (including inside counsel), costs, expenses, losses or liabilities attributable thereto) by any third party asserting or involving an IP right related to an acquired item. State shall allow Contractor to defend such claim so long as the defense is diligently and capably prosecuted. State shall allow Contractor to settle such claim so long as (i) all settlement payments are made by Contractor, and (ii) the settlement imposes no non-monetary obligation upon State. State shall reasonably cooperate with Contractor's defense of such claim.

(b) In the event an injunction or order shall be obtained against State's use of any acquired item, or if in Contractor's opinion, the acquired item is likely to become the subject of a claim of infringement or violation of an IP right, Contractor shall, without in any way limiting the foregoing, and at its expense, either: (1) procure for State the right to continue to use, or have used, the acquired item, or (2) replace or modify the acquired item so that it becomes non-infringing but only if the modification or replacement does not adversely affect the specifications for the acquired item or its use by State. If neither (1) nor (2), above, is practical, State may require that Contractor remove the acquired item from State, refund to State any charges paid by State therefor, and take all steps necessary to have State released from any further liability.

(c) Contractor's obligations under this paragraph do not apply to a claim to the extent (i) that the claim is caused by Contractor's compliance with specifications furnished by the State unless Contractor knew its compliance with the State's specifications would infringe an IP right, or (ii) that the claim is caused by Contractor's compliance with specifications furnished by the State if the State knowingly relied on a third party's IP right to develop the specifications provided to Contractor and failed to identify such product to Contractor.

(d) As used in this paragraph, these terms are defined as follows: "IP right(s)" means a patent, copyright, trademark, trade secret, or any other proprietary right. "Acquired item(s)" means the rights, goods, or services furnished under this agreement. "Specification(s)" means a detailed, exact statement of particulars such as a statement prescribing materials, dimensions, and quality of work. (e) Contractor's obligations under this clause shall survive the termination, cancellation, rejection, or expiration of this Agreement. [07-7B103-1]

#### **LICENSES AND PERMITS (JAN 2006):**

During the term of the contract, the Contractor shall be responsible for obtaining, and maintaining in good standing, all licenses (including professional licenses, if any), permits, inspections and related fees for each or any such licenses, permits and /or inspections required by the State, county, city or other government entity or unit to accomplish the work specified in this solicitation and the contract. [07-7B115-1]

#### **MATERIAL AND WORKMANSHIP (JAN 2006):**

Unless otherwise specifically provided in this contract, all equipment, material, and articles incorporated in the work covered by this contract are to be new and of the most suitable grade for the purpose intended. [07-7B120-1]

#### **PALLETIZING (JAN 2006):**

Palletized products must be furnished on hardwood pallets. [07-7B140-1]

#### **RELATIONSHIP OF THE PARTIES (JAN 2006):**

Neither party is an employee, agent, partner, or joint venturer of the other. Neither party has the right or ability to bind the other to any agreement with a third party or to incur any obligation or liability on behalf of the other party. [07-7B205-1]

#### **SHIPPING / RISK OF LOSS (JAN 2006):**

F.O.B. Destination. Destination is the shipping dock of the Using Governmental Units' designated receiving site, or other location, as specified herein. (See Delivery clause) [07-7B220-1]

#### **STORAGE OF MATERIALS (JAN 2006):**

Absent approval of the using governmental unit, Contractor shall not store items on the premises of the using governmental unit prior to the time set for installation. [07-7B235-1]

#### **SUBCONTRACTOR SUBSTITUTION PROHIBITED - RESIDENT SUBCONTRACTOR PREFERENCE (SEP 2009):**

If you receive an award as a result of the subcontractor preference, you may not substitute any business for the subcontractor upon which you relied to qualify for the preference, unless first approved in writing by the procurement officer. If you violate this provision, the State may terminate your contract for cause and you may be debarred. In addition, the procurement officer may require you to pay the State an amount equal to twice the difference between the price paid by the State and the price offered by the next lowest bidder, unless the substituted subcontractor qualifies for the preference. [11-35-1524(D)(5)(c)] [07-7B237-1]

#### **TERMINATION FOR CONVENIENCE – SHORT FORM (JAN 2006):**

The Procurement Officer may terminate this contract in whole or in part, for the convenience of the State. In such a termination, the Procurement Officer may require the contractor to transfer title and deliver to the State in the manner and to the extent directed by the Procurement Officer: (a) any completed supplies; and (b) such partially completed supplies and materials, parts, tools, dies, jigs, fixtures, plans, drawings, information, and contract rights (hereinafter called "manufacturing material") as the contractor has specifically produced or specially acquired for the performance of the terminated part of this contract. Upon such termination, the contractor shall (a) stop work to the extent specified, (b) terminate any subcontracts as



they relate to the terminated work, and (c) be paid the following amounts without duplication, subject to the other terms of this contract: (i) contract prices for supplies or services accepted under the contract, (ii) costs incurred in performing the terminated portion of the work, and (iii) any other reasonable costs that the contractor can demonstrate to the satisfaction of the State, using its standard record keeping system, have resulted from the termination. The contractor shall not be paid for any work performed or costs incurred that reasonably could have been avoided. As a condition of payment, contractor shall submit within three months of the effective date of the termination a claim specifying the amounts due because of the termination. The absence of an appropriate termination for convenience clause in any subcontract shall not increase the obligation of the state beyond what it would have been had the subcontract contained such a clause. [07-7B260-1]

**WARRANTY – STANDARD (JAN 2006):**

Contractor must provide the manufacturer's standard written warranty upon delivery of product. Contractor warrants that manufacturer will honor the standard written warranty provided. [07-7B280-1]

**VIII. Bidding Schedule**

<b>Lot</b>	<b>Quantity</b>	<b>UOM</b>	<b>Description</b>	<b>Unit Price</b>	<b>Extended Price</b>
<b>1</b>	<b>1</b>	<b>EA</b>	Fabricate Steel Beam-W8x18: Support for folding wall system per attached specification. Location for installation is in MUSC College of Health Professions Room A105  SC Made_____ US Made_____ No Reply_____	\$ _____	\$ _____
<b>1</b>	<b>1</b>	<b>EA</b>	Demolition	\$ _____	\$ _____
<b>1</b>	<b>1</b>	<b>EA</b>	Installation	\$ _____	\$ _____
<b>1</b>	<b>1</b>	<b>EA</b>	Shipping	\$ _____	\$ _____

**TOTAL:**

\_\_\_\_\_

**Company Name:** \_\_\_\_\_

## **IX. Attachments To Solicitation**

### **ATTACHMENTS LIST [09-9002-1]**

The following documents are attached to this solicitation: (list all attachments)

- Drawing of the plan for the steel beam-W8x18
- Nonresident Taxpayer Registration Affidavit Income Tax Withholdings
- Offeror's Checklist (JUN 2007)
- MUSC Campus Map

[REMAINDER OF PAGE INTENTIONALLY LEFT BLANK]

STRUCTURAL ABBREVIATIONS

AB	A. BOLT	IN	INCH
ADJ	ADJACENT	INCL	INCLUDE, ING
AFF	ABOVE FINISHED FLOOR	INT	INTERIOR
AHU	AIR HANDLING UNIT	LB	POUND
ALUM	ALUMINUM	LG	LONG
ALT	ALTERNATE	LL	LIVE LOAD
APPD	APPROVED	LLBB	LONG LEG BACK TO BACK
APPROX	APPROXIMATE	LLH	LONG LEG HORIZONTAL
ARCH	ARCHITECT	LLV	LONG LEG VERTICAL
		LONG	LONGITUDINAL
		LSL	LONG SLOTTED HOLES
		LT	LIGHT
		LTWT	LIGHTWEIGHT
B/BLDG	BOTTOM OF BUILDING	MAS	MASONRY
BM	BEAM	MAX	MAXIMUM
BOT	BOTTOM	MECH	MECHANICAL
BRDG	BRIDGING	MEZZ	MEZZANINE
BRG	BEARING	MFR	MANUFACTURER
BLK	BLOCK	MID	MIDDLE
BTWN	BETWEEN	MIN	MINIMUM
		MISC	MISCELLANEOUS
CANT	CANTILEVER	MJ	MASONRY JOINT
C/C	CENTER TO CENTER	MO	MASONRY OPENING
CHAM	CHAMFER		
CIRC	CIRCULAR	N	NORTH
CJ	CONTROL JOINT	NIC	NOT IN CONTRACT
CL	CLEAR	NO	NUMBER NOM NOMINAL
CMU	CONCRETE MASONRY UNITS	NS	NEAR SIDE
COL	COLUMN	NTS	NOT TO SCALE
CONC	CONCRETE	O/O	OUT TO OUT
CONN	CONNECTION	OC	ON CENTER
CONX	CONNECTION	OD	OUTSIDE DIAMETER
CONST	CONSTRUCTION	OP	OUTSIDE FACE
CONT	CONTINUOUS	OPNG	OPENING
CONTR	CONTRACTOR	OPP	OPPOSITE
COORD	COORDINATE	OW	OPEN WEB
CTRD	CENTERED	PAF	POWDER ACTUATED FASTENER
		PL	PLATE
D	DEPTH	PLF	POUNDS PER LINEAL FOOT
DBL	DOUBLE	PROJ	PROJECTION
DET	DETAIL	PSF	POUNDS PER SQUARE FOOT
DIA	DIAMETER	PSI	POUNDS PER SQUARE INCH
DIAG	DIAGONAL	PT	PRESSURE TREATED
DIM	DIMENSION	RAD	RADIUS
DL	DEAD LOAD	REF	REFERENCE
DWGS	DRAWINGS	REINF	REINFORCEMENT
		RET	RETURN
E	EAST	REV	REVISION
EA	EACH	RP	RADIUS POINT
EB	EXPANSION BOLT	RT	RIGHT
EF	EACH FACE	RTU	ROOF TOP UNIT
EJ	EXPANSION JOINT	S	SOUTH
EL	ELEVATION	SA	SLEEVE ANCHOR
ELEV	ELEVATOR	SB	SLAB BOLSTER
EMBED	EMBEDMENT	SCHED	SCHEDULE
ENGR	ENGINEER	SECT	SECTION
EOS	EDGE OF SLAB	SF	STEP FOOTING
EQ	EQUAL	SIM	SIMILAR
EQUIP	EQUIPMENT	SPEC	SPECIFICATIONS
EQUIV	EQUIVALENT	SP	SPACING,ES
ES	EACH SIDE	SQ	SQUARE
EW	EACH WAY	SSL	SHORT SLOTTED HOLES
EXP	EXPANSION	SS	STAINLESS STEEL
EXIST	EXISTING	STD	STANDARD
EXT	EXTERIOR	STIFF	STIFFENERS
		STL	STEEL
		STR	STRUCTURAL
		SYMM	SYMMETRICAL
FC	FILLED CELL	T/	TOP OF
FF	FINISHED FLOOR	TB	TIE BEAM
FIN	FINISH	TC	TIE COLUMN
FLR	FLOOR	TCX	TOP CHORD EXTENSION
FDN	FOUNDATION	T&B	TOP AND BOTTOM
FRG	FRAMING	TEMP	TEMPORARY
FT	FEET	TRNSV	TRANSVERSE
FTG	FOOTING	TS	TUBE STEEL
FV	FIELD VERIFY	TP	TYPICAL
		TD	PRESSURE TREATED
GALV	GALVANIZED	UNO	UNLESS NOTED OTHERWISE
GA	GAUGE	VERT	VERTICAL
		W	WEST
HORIZ	HORIZONTAL	WTH	WIDTH
HSA	HEADED STUD ANCHOR	W/	WITH
HSB	HIGH STRENGTH BOLT	W/O	WITHOUT
HT	HEIGHT	WP	WORK POINT
		WS	WATERSTOP
ID	INSIDE DIAMETER	WT	WEIGHT
IF	INSIDE FACE	WWF	WELDED WIRE FABRIC

STRUCTURAL DESIGN CRITERIA

- GRAVITY LOAD DESIGN VALUES: IBC-2015/ ASCE 7-10  
LIVE LOADS:  
OFFICES 50-PSF  
CORRIDOR 80-PSF  
FOLDING PARTITION DOOR 125-LB/LF MAX WEIGHT  
SEE PLAN FOR ADDITIONAL FLOOR AND ROOF LIVE LOAD LOADING REQUIREMENTS.  
DEAD LOADS:  
ACTUAL MATERIAL WEIGHTS  
SOIL BEARING PRESSURE, (ALLOWABLE): PILE FOUNDATION (EXISTING, ASSUMED)
- SEISMIC DESIGN VALUES: IBC-2015/ ASCE 7-10  
Ss = 1.126g, Sds = 0.788g  
S1 = 0.358g, Sd1 = 0.402g  
SITE CLASS: "D"  
BUILDING CATEGORY: "III"  
SEISMIC DESIGN CATEGORY: "D"  
SEISMIC FORCE RESISTING SYSTEM (EXISTING CHP BUILDING): ASCE 7-10  
SPECIALLY REINFORCED CONCRETE SHEAR WALLS (EXISTING, ASSUMED)  
R = 6 (EXISTING SYSTEM, ASSUMED)  
Cd = 5 (EXISTING SYSTEM, ASSUMED)  
I = 1.25 (EXISTING SYSTEM, ASSUMED)  
TL = 8.0 (EXISTING SYSTEM, ASSUMED)  
Cs = .164 (EXISTING SYSTEM, ASSUMED)  
SEISMIC FORCE ON NONSTRUCTURAL COMPONENT (FOLDING PARTITION DOOR): ASCE 7-10 (CHAPTER 13&15)  
FOLDING PARTITION DOOR  
Rp = 2.5  
qp = 1.0  
Ip = 1.5  
Fp = 2.24 KIPS
- WIND LOAD DESIGN VALUES: IBC-2015 (MWFRS)/ ASCE 7-10 (MWFRS)  
V(ult) = 158 mph (3-sec gust) (MWFRS)  
EXPOSURE CATEGORY: "B"  
BUILDING CATEGORY: "III"  
I = 1.00  
Gcpi = +/- .18  
q(ult) = 44.0 - PSF      qi(ult) = 7.9 - PSF

GENERAL NOTES:

- STRUCTURAL DRAWINGS SHALL BE USED IN CONJUNCTION WITH ARCHITECTURAL AND MECHANICAL DRAWINGS AND DRAWINGS RELATING TO OTHER TRADES. CONTRACTOR SHALL BE RESPONSIBLE FOR CHECKING AND COORDINATING DIMENSIONS, CLEARANCES, ETC. WITH THE WORK OF OTHER TRADES. IN CASE OF CONFLICT BETWEEN DRAWINGS, THE MORE STRINGENT REQUIREMENT SHALL GOVERN.
- IN CASE OF CONFLICT BETWEEN THE DRAWINGS, NOTES AND SPECIFICATIONS, THE SPECIFICATIONS SHALL GOVERN.
- WORK NOT INDICATED ON A PART OF THE DRAWINGS BUT REASONABLY IMPLIED TO BE SIMILAR TO THAT SHOWN AT CORRESPONDING PLACES SHALL BE REPEATED.
- REVIEW ALL PROJECT DOCUMENTS PRIOR TO FABRICATION AND START OF CONSTRUCTION. REPORT ANY DISCREPANCIES TO A/E PRIOR TO PROCEEDING WITH WORK.
- IT IS THE PRIME CONTRACTOR'S RESPONSIBILITY TO PROTECT EXISTING FACILITIES, STRUCTURES AND UTILITY LINES FROM ALL DAMAGE DURING CONSTRUCTION.
- COORDINATE STRUCTURAL AND OTHER DRAWINGS THAT ARE PART OF THE CONTRACT DOCUMENTS FOR ANCHORED, EMBEDDED OR SUPPORTED ITEMS WHICH MAY AFFECT THE STRUCTURAL DRAWINGS.
- ALL DETAILS AND SECTIONS ON THE DRAWINGS ARE INTENDED TO BE TYPICAL AND SHALL BE CONSTRUED TO APPLY TO ANY SIMILAR SITUATION ELSEWHERE ON THE PROJECT EXCEPT WHERE A SEPARATE DETAIL IS SHOWN.
- USE OF CONTRACT DRAWINGS REPRODUCED IN WHILE OR ANY PART IN SHOP DRAWING SHALL NOT RELIEVE THE CONTRACTOR OR SUBCONTRACTORS FROM THEIR RESPONSIBILITY TO ACCURATELY LAYOUT, COORDINATE, DETAIL, FABRICATE AND INSTALL A COMPLETE STRUCTURE.
- REVIEW ALL SHOP DRAWINGS FOR CONFORMANCE WITH THE CONTRACT DOCUMENTS AND FOR COMPLETENESS AND ANSWER ALL CONTRACTOR RELATED QUESTIONS. STAMP AND INITIAL ALL SHEETS PRIOR TO SUBMITTING SHOP DRAWINGS TO OR A/E FOR REVIEW.

STRUCTURAL STEEL:

- ALL STRUCTURAL STEEL WORK SHALL CONFORM TO THE SPECIFICATIONS FOR THE DESIGN, FABRICATION, AND ERECTION OF STRUCTURAL STEEL FOR BUILDINGS, CURRENT EDITION, OF THE A.I.S.C.
- WELDS, BOTH SHOP AND FIELD, SHALL CONFORM TO THE A.W.S SPECIFICATIONS. ALL WELDS SHALL BE DONE WITH E-70 ELECTRODES
- STRUCTURAL STEEL SHOP DRAWINGS ARE REQUIRED AND SHALL BE SUBMITTED TO THE A/E FOR APPROVAL PRIOR TO FABRICATION. SHOP DRAWINGS SHALL NOT BE A REPRODUCTION OF THE CONTRACT DOCUMENTS. THE GENERAL CONTRACTOR SHALL REVIEW AND STAMP ALL SHOP DRAWINGS AND SUBMITTALS "APPROVED" PRIOR TO SUBMITTING TO ARCHITECT FOR REVIEW.
- (NOTE NOT USED.)
- STRUCTURAL STEEL MATERIALS SHALL CONFORM TO THE FOLLOWING ASTM SPECIFICATION (U.N.O.):  
WIDE FLANGES, STRUCTURAL TIES ASTM A992, FY=50 KSI  
ANGLES, PLATES, MISC. STEEL ASTM A36, FY=36 KSI  
THRD'D RODS ASTM A36, FY=36 KSI  
TUBES/HSS ASTM A500, GRADE B  
PIPES ASTM A53, TYPE E OR S.  
ANCHOR BOLTS ASTM A449  
HIGH STRENGTH BOLTS ASTM A325 TYPE 1
- PROVIDE STIFFENER PLATES ON EACH SIDE OF WEB, BEAM OR GIRDER AT POINTS OF CONCENTRATED LOADS. MINIMUM STIFFENER PLATE THICKNESS SHALL BE 1/2" OR FLANGE THICKNESS OF SUPPORTING MEMBER, WHICHEVER IS GREATER, U.N.O.
- PROVIDE TEMPORARY BRACING OR GUYS TO PROVIDE LATERAL SUPPORT UNTIL PERMANENT LATERAL BRACING IS INSTALLED.
- THE PRIME CONTRACTOR SHALL PROVIDE WEB REINFORCEMENT AT OPENINGS IN STEEL BEAMS AND GIRDERS FOR MECHANICAL AND ELECTRICAL PENETRATIONS IF INDICATED ON MECHANICAL, STRUCTURAL OR ELECTRICAL DRAWINGS. ALL OPENINGS SHALL BE LOCATED AT THE CENTER OF THE BEAM WEB DEPTH.
- THE PRIME CONTRACTOR SHALL COORDINATE THE BOTTOM OF BASE PLATE ELEVATION WITH THE TOP OF CONCRETE ELEVATION. IN CASE OF CONFLICT, THE CONTRACTOR SHALL MAKE ALLOWANCE IN HIS BID FOR THE MORE STRINGENT REQUIREMENT.
- CUTS, HOLES, COPING, ETC. REQUIRED FOR WORK OF OTHER TRADES SHALL BE SHOWN ON THE SHOP DRAWINGS AND MADE IN THE SHOP. CUTS OR BURNING HOLES IN STRUCTURAL STEEL MEMBERS IN THE FIELD WILL NOT BE PERMITTED.
- ALL STEEL DETAILS AND CONNECTIONS SHALL BE IN ACCORDANCE WITH THE REQUIREMENT OF THE AISC SPECIFICATIONS (LATEST EDITION), INCLUDING ALL SUPPLEMENTS AND REVISIONS.
- SHOP CONNECTIONS NOT SPECIFICALLY DETAILED ON THE DRAWINGS MAY BE WELDED OR BOLTED UPON APPROVAL OF THE A/E. FIELD CONNECTIONS NOT SPECIFICALLY DETAILED ON THE DRAWING SHALL BE BOLTED UPON APPROVAL OF THE A/E.
- BEAM CONNECTIONS SHALL BE 3/4" DIAMETER A325 TYPE CONNECTION BOLT UNLESS OTHERWISE NOTED. ALL BEAM AND GIRDER CONNECTIONS, UNLESS SHOWN OTHERWISE, SHALL BE AT LEAST CAPABLE OF DEVELOPING THE UNIFORMLY DISTRIBUTED LOADING CAPACITY OF MEMBER OF ITS SPAN AS PER AISC MANUAL OF STEEL CONSTRUCTION (LATEST EDITION).
- ALTERNATE CONNECTION DETAILS MAY BE USED IF SUCH DETAILS ARE SUBMITTED TO THE A/E FOR REVIEW AND ACCEPTANCE IS GRANTED. HOWEVER, THE A/E SHALL BE THE SOLE JUDGE OF ACCEPTABILITY AND THE PRIME CONTRACTOR'S BID SHALL ANTICIPATE THE USE OF THESE SPECIFIC DETAILS SHOWN ON THE DRAWINGS. IN ANY EVENT, THE CONTRACTOR SHALL BE RESPONSIBLE FOR THE DESIGN OF SUCH ALTERNATE DETAILS WHICH HE PROPOSES.
- FOR LOCATION OF LINTELS, SEE ARCHITECTURAL DRAWINGS. FOR SIZE OF LINTELS, SEE SCHEDULE. HUNG LINTELS SHALL BE PROVIDED AND INSTALLED BY STRUCTURAL STEEL CONTRACTOR. LOOSE LINTELS SHALL BE SUPPLIED AND INSTALLED BY MISCELLANEOUS IRON AND STEEL CONTRACTOR.
- STEEL FABRICATOR SHALL SUPPLY ANCHOR BOLT LOCATION DRAWINGS.
- BOTTOMS OF ALL COLUMNS SHALL BE MILLED.
- FILLET WELD SIZES NOT CALLED OUT HEREIN SHALL BE 3/16" MINIMUM.

FIELD WELDING:

- ALL FIELD WELDING SHALL BE IN ACCORDANCE WITH AWS D1.1 STRUCTURAL WELDING CODE (LATEST EDITION)
- WELDING SHALL BE PERFORMED BY QUALIFIED WELDERS. CONTRACTOR SHALL SUBMIT WELDING CERTIFICATES FOR APPROVAL.
- ALL WELDING ELECTRODES SHALL BE E70 WITH A MINIMUM YIELD STRENGTH OF 58KSI, MINIMUM TENSILE STRENGTH OF 70 KSI, AND MINIMUM ELONGATION OF 22% IN ACCORDANCE WITH AWS A5.
- FIELD WELDING SHALL BE SHOWN ON ERECTION DRAWINGS.
- REPAIR ALL DAMAGED PRIMER AT ADJACENT AREAS AFTER WELD INSPECTION IS COMPLETE.
- MINIMUM WELD FOR FRAMING AND MISCELLANEOUS STEEL SHALL BE 3/16" FILLET WELD ALL AROUND UNLESS NOTED OTHERWISE.
- ALL WELD FILLER METAL SHALL HAVE A MINIMUM CVN TOUGHNESS OF 20 FT-LBS AT MINUS 10 DEGREES FAHRENHEIT AND 40 FT-LB AT 70° FAHRENHEIT.
- THE PRIME CONTRACTOR SHALL SCHEDULE WELD TESTING AND INSPECTION SUCH THAT REPORTS MAY BE REVIEWED BY THE EOR AND APPROVAL OR RECOMMENDATION FOR FURTHER TESTING OR REMEDIAL ACTION MAY BE MADE WHILE WELDS ARE STILL ACCESSIBLE.
- SUBCONTRACTOR SHALL SUBMIT DETAIL WELD PROCEDURE FOR EACH TYPE OF WELD TO BE COMPLETED. INFORMATION SHALL BE MADE AVAILABLE TO THE WELD INSPECTOR.
- TESTING AND INSPECTION OF FIELD WELDS SHALL BE CONDUCTED BY AN INDEPENDENT TESTING AGENCY (COMMISSIONED BY THE OWNER) IN ACCORDANCE WITH THE SCHEDULE OF SPECIAL INSPECTIONS.

**GENERAL NOTE:**

THE G.C. SHALL FIELD VERIFY ALL EXISTING STEEL ELEVATIONS AND DIMENSIONS

THE G.C. SHALL COORD. NEW EQUIPMENT LAYOUT W/ EXISTING STEEL.

THE G.C. SHALL COORD. FOLDING PARTITION DOOR EQUIPMENT LAYOUT AND ATTACHMENT TO NEW STEEL PRIOR TO STEEL FABRICATION.

ALL ITEMS SHALL BE VERIFIED PRIOR TO NEW STEEL FABRICATION.

**CONTRACTOR NOTE:**

THE G.C. SHALL PROVIDE TOUCH UP COATINGS AS REQUIRED AT LOCATIONS OF SCRATCHES, WELDS AND ANY OTHER DAMAGED OR UNCOATED AREA DUE TO A CONNECTION, OR CONTACT WITH AN ALTERNATE MATERIAL, ETC..

THE G.C. SHALL REPLACE FIREPROOFING AS REQUIRED AT LOCATIONS OF FIREPROOFING REMOVAL FOR THE INSTALLATION OF NEW FRAMING.

NEW FIRE PROOFING SHALL MATCH EXISTING ADJACENT

MUSCH CHP  
Charleston, South Carolina

MUSCH CHP 1ST FLOOR FOLDING PARTITION  
DOOR (ROOM 105)

CHARLESTON  
SOUTH CAROLINA



**ADC**  
ENGINEERING SPECIALISTS

SITE SERVICES \ BUILDING ENVELOPE \ STRUCTURAL

1224 YEAMANS HALL ROAD  
HANAHAN, SC 29410  
843-566-0161  
fax 843-566-0162  
ADCENGINEERING.COM

DATE:	4-27-2018
ADC PROJECT #:	18026.0
DESIGNED:	CJG
CHECKED:	CJG
DRAWN:	VG
REVISION:	
REVISED	09.04.2018
REVISED	09.10.2018

GENERAL NOTES  
AND  
DESIGN CRITERIA

S000

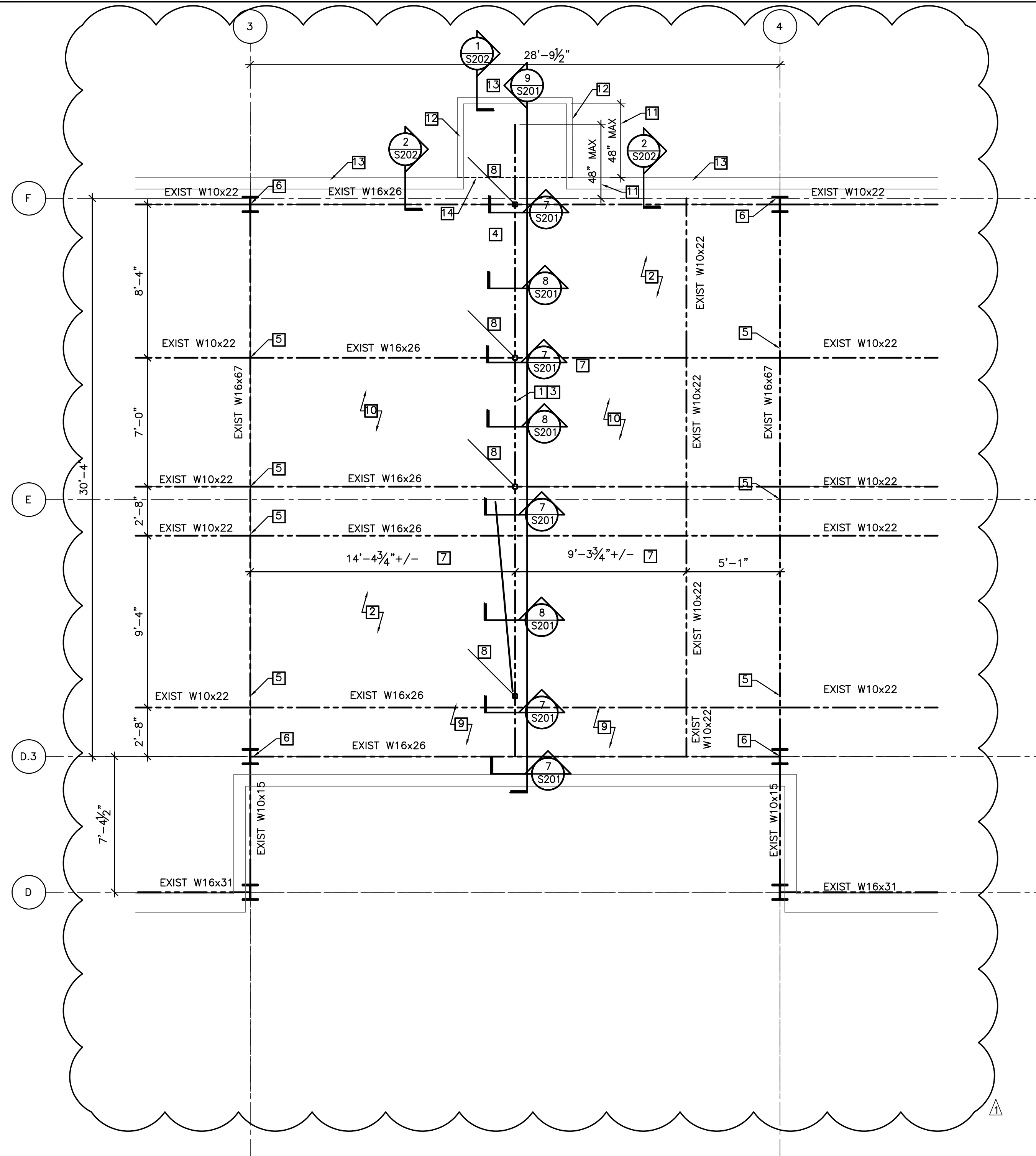

1 SECOND FLOOR FRAMING PLAN

S101

SCALE: 1/4" = 1'-0"

**DRAWING NOTES:**

APPLY TO THIS DRAWINGS ONLY

- 1 NEW W8x18, CONT.
- 2 EXISTING SLAB ABOVE
- 3 MAXIMUM DOOR WEIGHT = 125-LBS/FT
- 4 DOOR TO STACK IN THIS LOCATION. IF OWNER WANTS ALTERNATE LOCATION, NOTIFY EOR SO ALTERNATE PLAN MAY BE PROVIDED.
- 5 PROVIDE ADDITIONAL WELD @ CONNECTION OF EXISTING BEAM TO EXISTING BEAM PER TYPICAL DETAIL 1/S201.
- 6 PROVIDE ADDITIONAL WELD @ CONNECTION OF EXISTING BEAM TO EXISTING COLUMN PER TYPICAL DETAIL 4/S201.
- 7 G.C. TO COORDINATE WITH OWNER FOR EXACT DOOR LOCATION.
- 8 HSS 3x3x1/4 HANGER.
- 9 G.C. TO REMOVE AND REPLACE GYP. CEILING AS REQUIRED. REPLACE TO MATCH EXISTING ADJACENT.
- 10 G.C. TO REMOVE AND REPLACE DROP CEILING. REPLACE TO MATCH EXISTING ADJACENT.
- 11 G.C. TO COORDINATE W/ DOOR SUPPLIER.
- 12 362S162x20GA METAL STUDS @ 16"o.c.
- 13 INFILL METAL STUD FRAMING W/ 362S162x20GA STUDS @ 16"o.c.
- 14 G.C. SHALL MOVE CONDUIT & WIRING SO AS NOT TO INTERFERE W/ NEW BEAM & DOOR. G.C. TO FIELD LOCATE NEW CONDUIT & EXTENT.

**ELEVATIONS:**

- T/1ST FLOOR SLAB = 0'-0"
- T/DOOR = 9'-8 1/2" ±
- B/NEW BEAM (W8x18) = 10'-3" ±
- B/EXISTING CONDUIT = 10'-1 1/4" ± G.C. TO F.V.
- T/EXISTING W16x26 = 15'-1 1/4" ± G.C. TO F.V.

MUSCH, C.H.P.  
Charleston, South Carolina

MUSC CHP 1ST FLOOR FOLDING PARTITION  
DOOR (ROOM 105)

CHARLESTON  
SOUTH CAROLINA

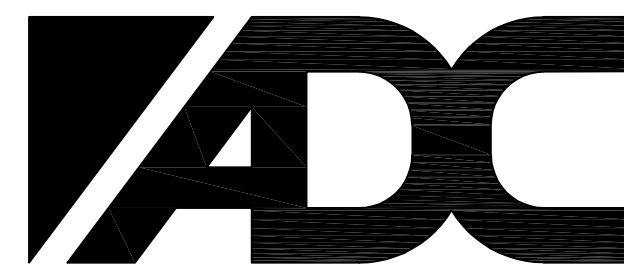
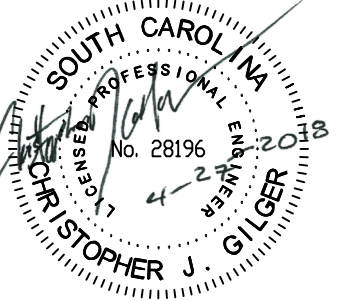
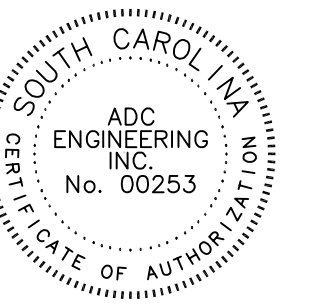

**ADC**  
ENGINEERING SPECIALISTS  
SITE SERVICES \ BUILDING ENVELOPE \ STRUCTURAL  
1224 YEAMANS HALL ROAD  
HANAHAN, SC 29410  
843-566-0161  
fax 843-566-0162  
ADCEngineering.com

DATE: 4-27-2018

ADC PROJECT #: 18026.0

DESIGNED: C/JG

CHECKED: C/JG

DRAWN: VG

REVISION:

REVISED 09.04.2018

△ REVISED 09.10.2018

SECOND FLOOR  
FRAMING PLAN

S101

NOTE:  
G.C. TO VERIFY CONNECTION IS MINIMUM 3/8" TAB PLATE, W/  
3-3/4" A325 STD. BOLTS. IF CONNECTION IS NOT AS  
INDICATED, NOTIFY A/E FOR ALTERNATE CONNECTION. G.C. TO  
PROVIDE ALLOWANCE IN BID OF \$2000.00 PER CONNECTION FOR  
ALTERNATE CONNECTION

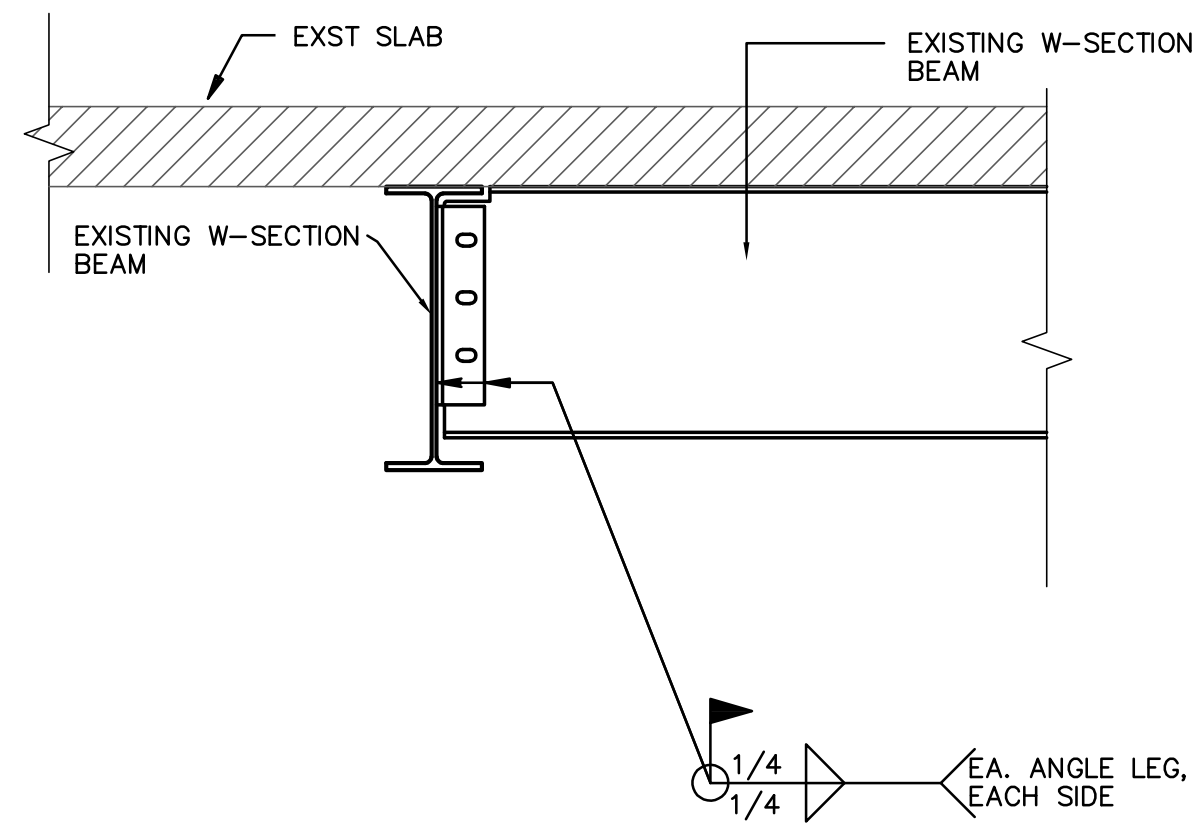

1 SECTION (TYPICAL)  
SCALE: 1"=1'-0"

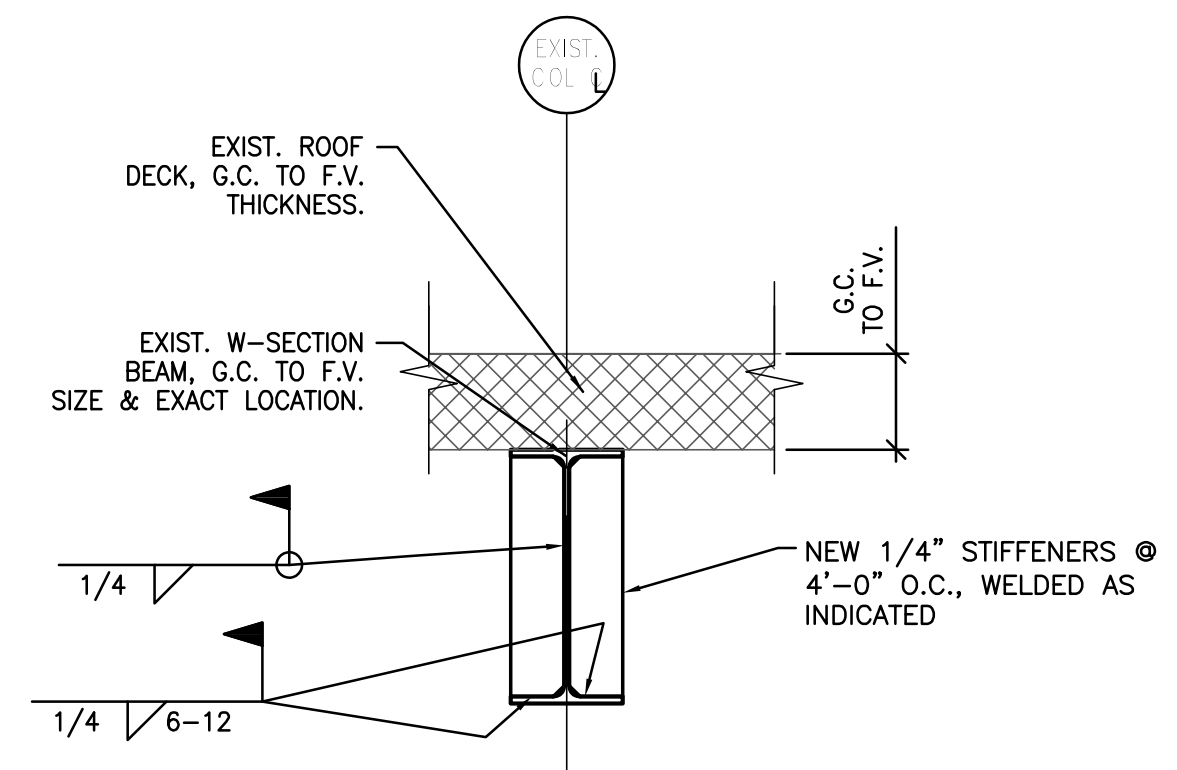

2 SECTION (TYPICAL)  
SCALE: 1"=1'-0"

NOTE:  
G.C. TO VERIFY CONNECTION IS MINIMUM 3/8"  
TAB PLATE, W/ 4-3/4" A325 STD. BOLTS.  
IF CONNECTION IS NOT AS INDICATED, NOTIFY  
A/E FOR ALTERNATE CONNECTION. G.C. TO  
PROVIDE ALLOWANCE IN BID OF \$2000.00 PER  
CONNECTION FOR ALTERNATE CONNECTION

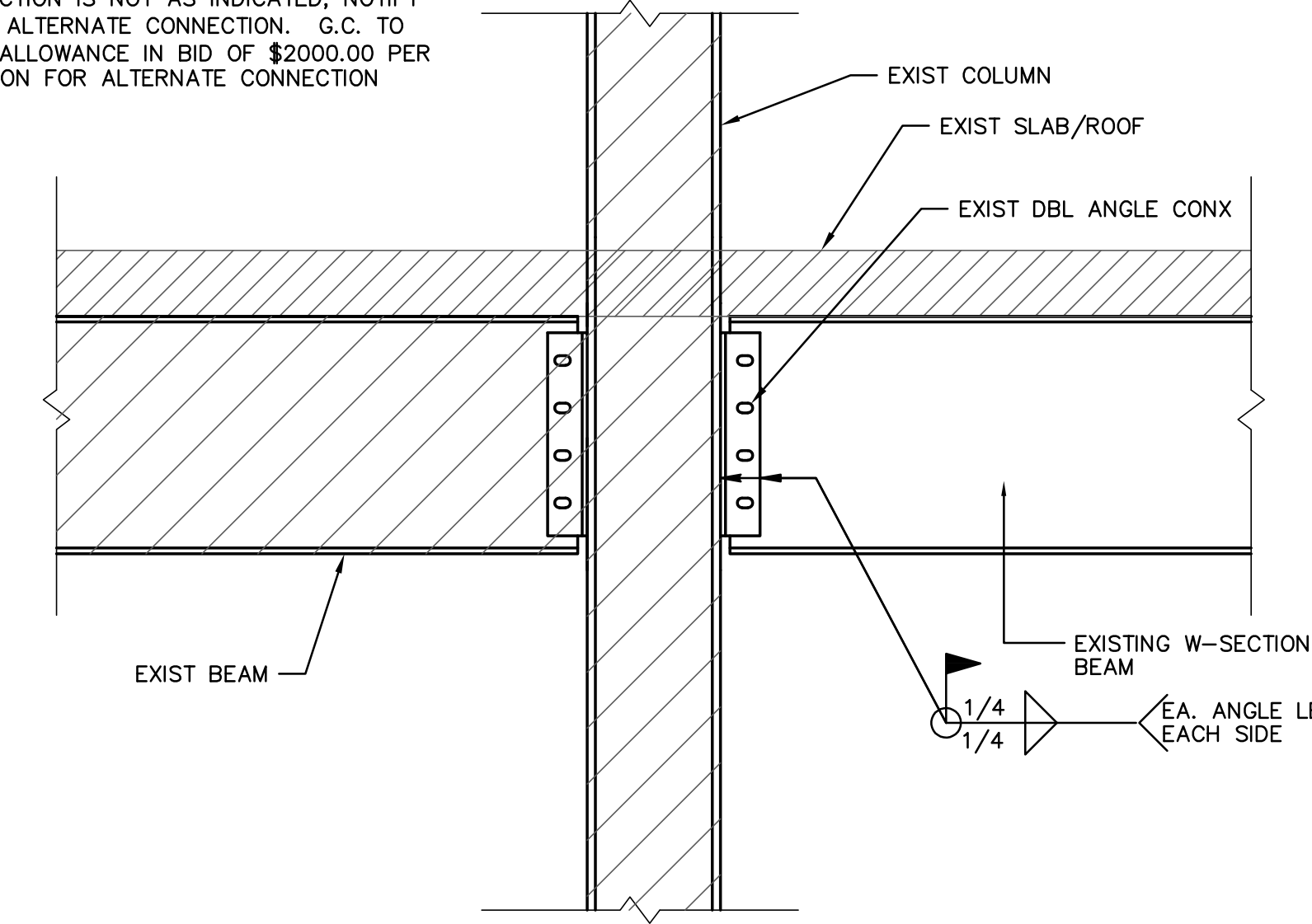

4 SECTION (TYPICAL)  
SCALE: 1"=1'-0"

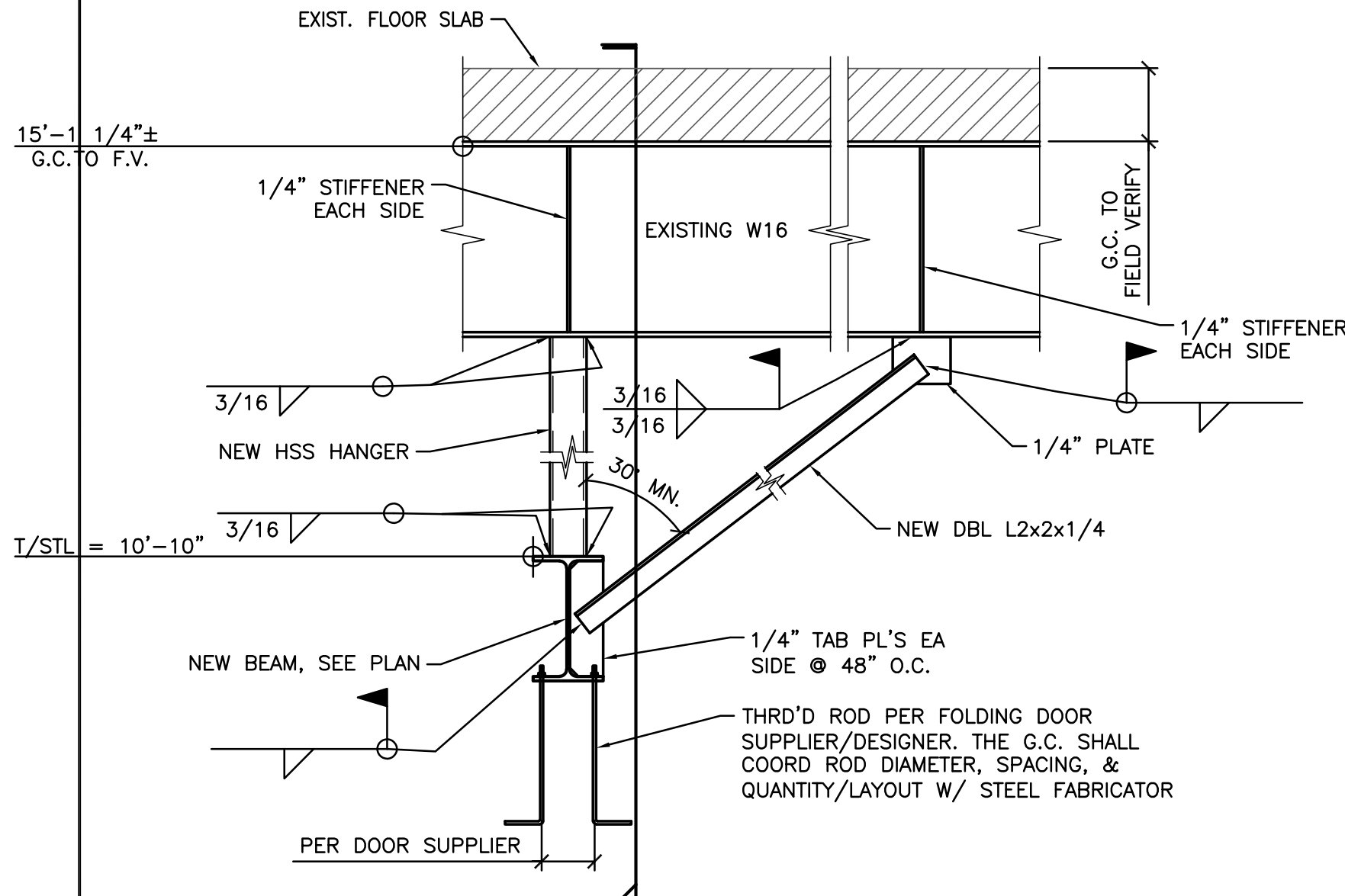

7 SECTION (TYPICAL)  
SCALE: 1"=1'-0"

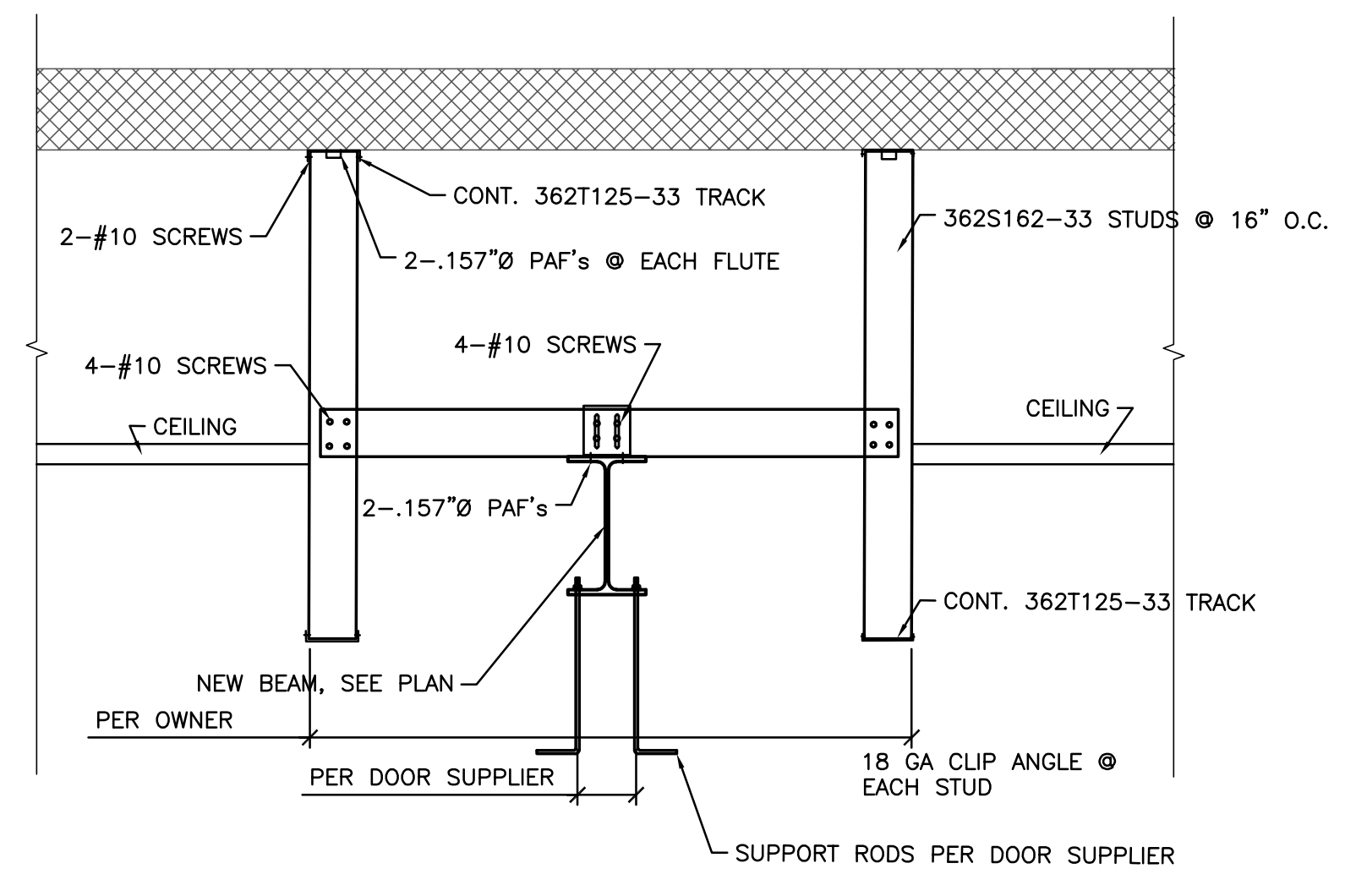

8 SECTION (TYPICAL)  
SCALE: 1"=1'-0"

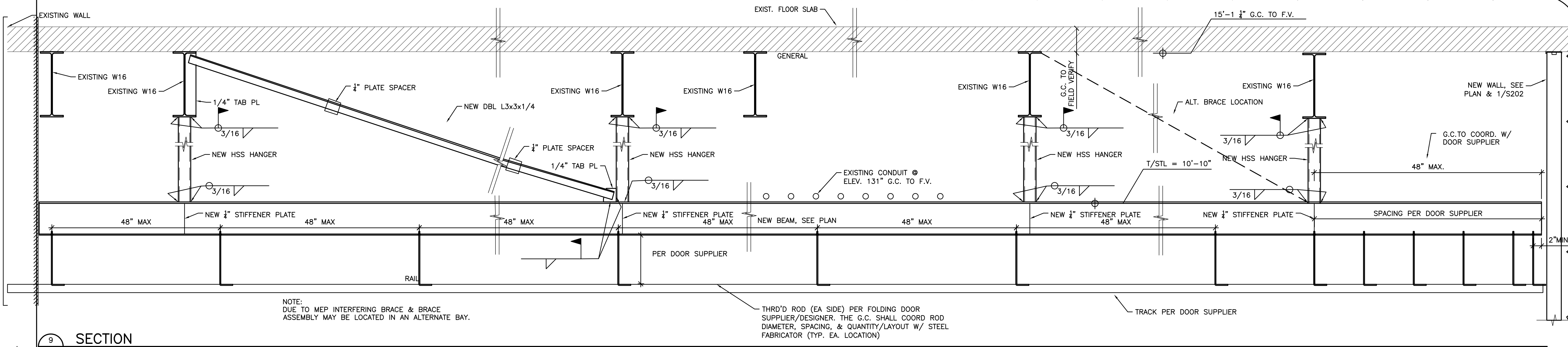

9 SECTION  
SCALE: 1"=1'-0"

NOTE:  
DUE TO MEP INTERFERING BRACE & BRACE  
ASSEMBLY MAY BE LOCATED IN AN ALTERNATE BAY.

THRD'D ROD (EA SIDE) PER FOLDING DOOR  
SUPPLIER/DESIGNER. THE G.C. SHALL COORD ROD  
DIAMETER, SPACING, & QUANTITY/LAYOUT W/ STEEL  
FABRICATOR (TYP. EA. LOCATION)

TRACK PER DOOR SUPPLIER

MUSCH CHP  
Charleston, South Carolina

MUSCH CHP 1ST FLOOR FOLDING PARTITION  
DOOR (ROOM 105)

CHARLESTON  
SOUTH CAROLINA

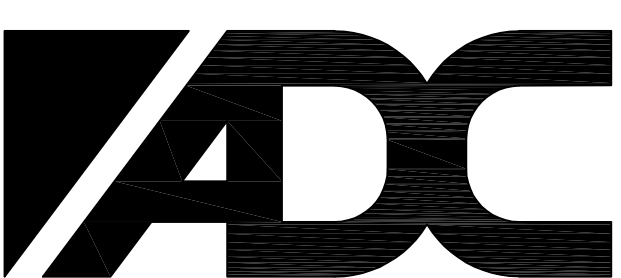
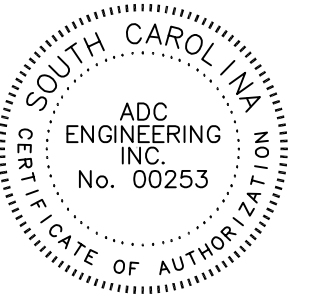

ENGINEERING SPECIALISTS  
SITE SERVICES \ BUILDING ENVELOPE \ STRUCTURAL  
1226 YEAMANS HALL ROAD  
HANAHAN, SC 29410  
843-566-0161  
Fax 843-566-0162  
ADCENGINEERING.COM

DATE:	4-27-2018
ADC PROJECT #:	18026.0
DESIGNED:	CJG
CHECKED:	CJG
DRAWN:	VG
REVISION:	
REVISED	09.04.2018
REVISED	09.10.2018

TYPICAL SECTIONS  
AND DETAILS

S201

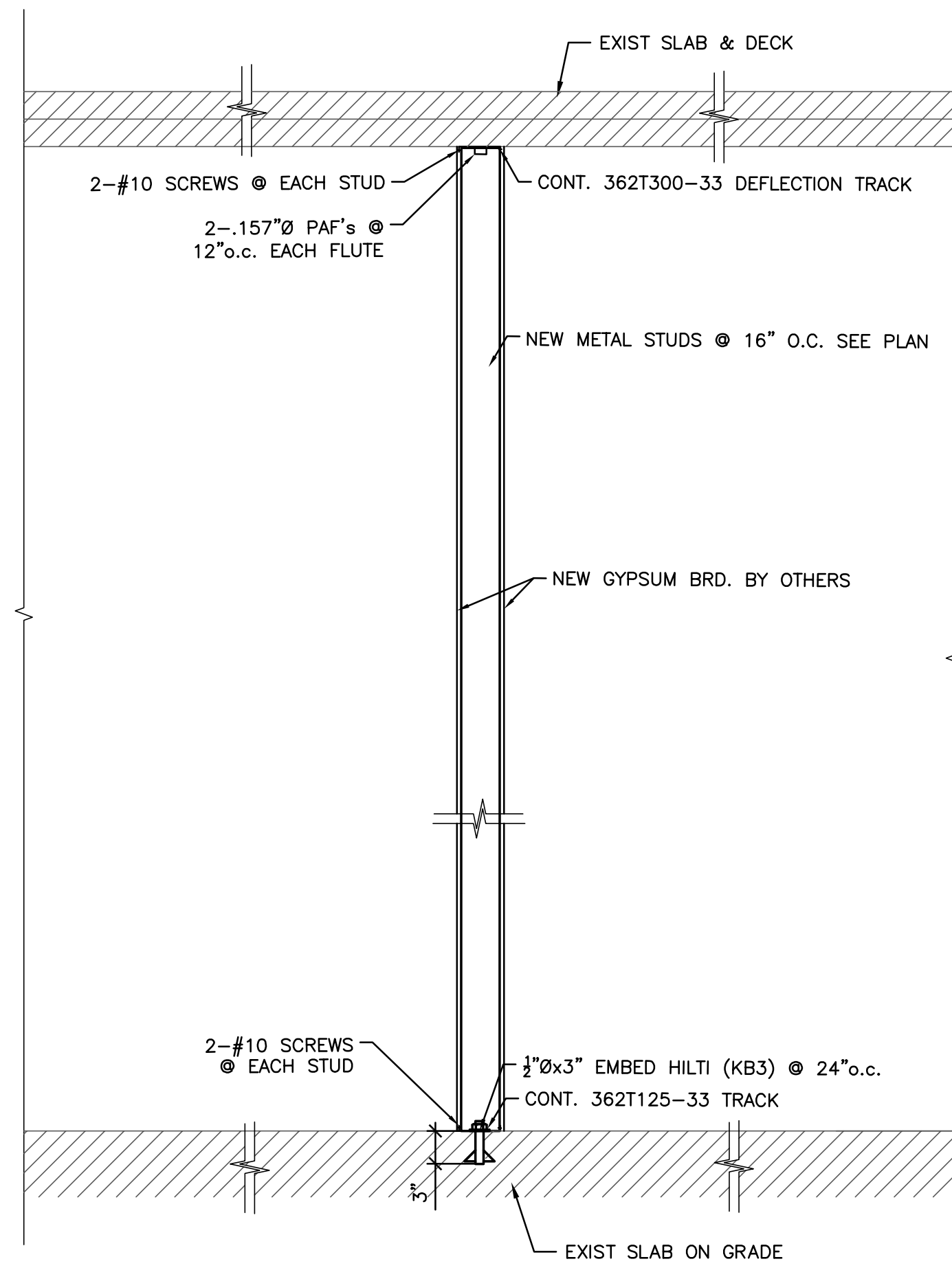

1 SECTION (TYPICAL) SCALE: 1"=1'-0"

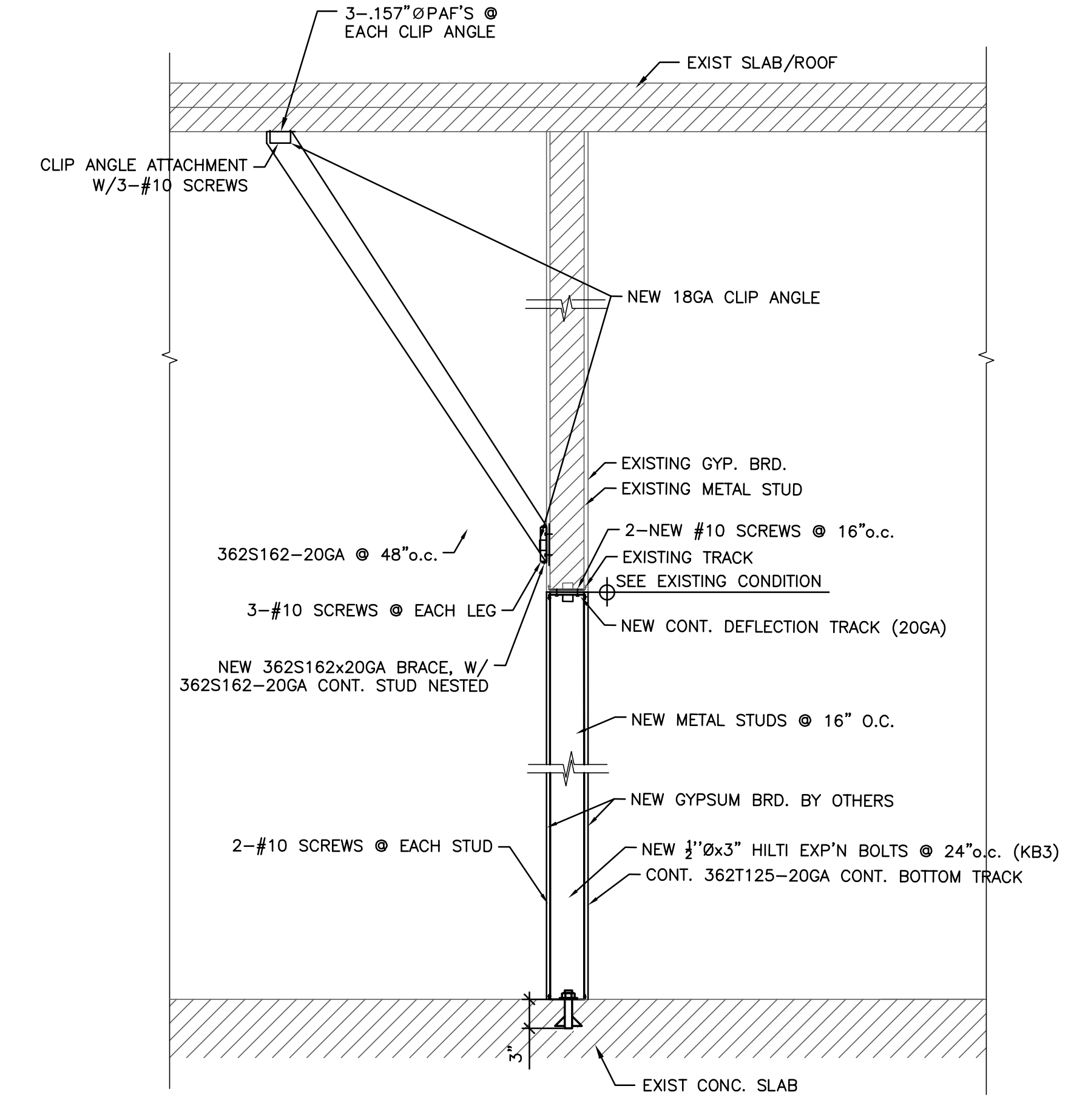

2 SECTION (TYPICAL) SCALE: 1"=1'-0"

MUSCH, CHP  
Charleston, South Carolina

MUSCH CHP 1ST FLOOR FOLDING PARTITION  
DOOR (ROOM 105)

CHARLESTON  
SOUTH CAROLINA

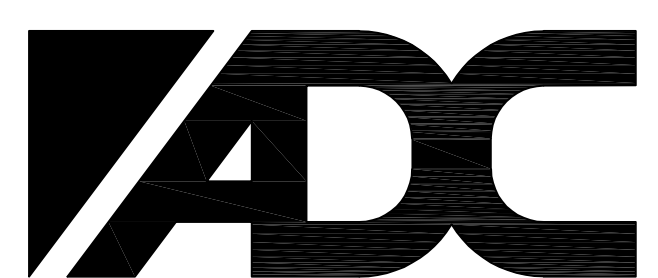
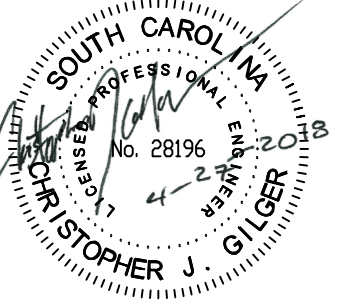
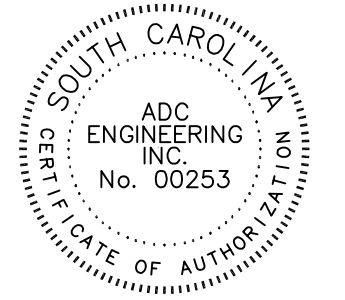

**ADC**  
ENGINEERING SPECIALISTS  
SITE SERVICES \ BUILDING ENVELOPE \ STRUCTURAL  
1224 YEAMANS HALL ROAD  
HANAHAN, SC 29410  
843-566-0161  
fax 843-566-0162  
ADCEngineering.com

DATE:	4-27-2018
ADC PROJECT #:	18026.0
DESIGNED:	CJG
CHECKED:	CJG
DRAWN:	VG
REVISION:	
REVISED	09.04.2018
REVISED	09.10.2018

TYPICAL SECTIONS  
AND DETAILS

S202

IMPORTANT TAX NOTICE - NONRESIDENTS ONLY

Withholding Requirements for Payments to Nonresidents: Section 12-8-550 of the South Carolina Code of Laws requires persons hiring or contracting with a nonresident conducting a business or performing personal services of a temporary nature within South Carolina to withhold 2% of each payment made to the nonresident. The withholding requirement does not apply to (1) payments on purchase orders for tangible personal property when the payments are not accompanied by services to be performed in South Carolina, (2) nonresidents who are not conducting business in South Carolina, (3) nonresidents for contracts that do not exceed \$10,000 in a calendar year, or (4) payments to a nonresident who (a) registers with either the S.C. Department of Revenue or the S.C. Secretary of State and (b) submits a Nonresident Taxpayer Registration Affidavit - Income Tax Withholding, Form I-312 to the person letting the contract.

The withholding requirement applies to every governmental entity that uses a contract ("Using Entity"). Nonresidents should submit a separate copy of the Nonresident Taxpayer Registration Affidavit - Income Tax Withholding, Form I-312 to every Using Entity that makes payment to the nonresident pursuant to this solicitation. Once submitted, an affidavit is valid for all contracts between the nonresident and the Using Entity, unless the Using Entity receives notice from the Department of Revenue that the exemption from withholding has been revoked.

-----

Section 12-8-540 requires persons making payment to a nonresident taxpayer of rentals or royalties at a rate of \$1,200.00 or more a year for the use of or for the privilege of using property in South Carolina to withhold 7% of the total of each payment made to a nonresident taxpayer who is not a corporation and 5% if the payment is made to a corporation. Contact the Department of Revenue for any applicable exceptions.

-----

For information about other withholding requirements (e.g., employee withholding), contact the Withholding Section at the South Carolina Department of Revenue at 803-898-5383 or visit the Department's website at [www.sctax.org](http://www.sctax.org).

-----

This notice is for informational purposes only. This agency does not administer and has no authority over tax issues. All registration questions should be directed to the License and Registration Section at 803-898-5872 or to the South Carolina Department of Revenue, Registration Unit, Columbia, S.C. 29214-0140. All withholding questions should be directed to the Withholding Section at 803-898- 5383.

[www.dor.sc.gov](http://www.dor.sc.gov)



# OFFEROR'S CHECKLIST

## AVOID COMMON BIDDING MISTAKES

Review this checklist prior to submitting your bid.  
If you fail to follow this checklist, you risk having your bid rejected.

DO NOT INCLUDE ANY OF YOUR STANDARD CONTRACT FORMS!

UNLESS EXPRESSLY REQUIRED, DO NOT INCLUDE ANY ADDITIONAL BOILERPLATE CONTRACT CLAUSES.

REREAD YOUR ENTIRE BID TO MAKE SURE YOUR BID DOES NOT TAKE EXCEPTION TO ANY OF THE STATE'S MANDATORY REQUIREMENTS.

MAKE SURE YOU HAVE PROPERLY MARKED ALL PROTECTED, CONFIDENTIAL, OR TRADE SECRET INFORMATION IN ACCORDANCE WITH THE HEADING ENTITLED: FOIA BIDDING INSTRUCTIONS, SUBMITTING CONFIDENTIAL INFORMATION. **DO NOT MARK YOUR ENTIRE BID AS CONFIDENTIAL, TRADE SECRET, OR PROTECTED! DO NOT INCLUDE A LEGEND ON THE COVER STATING THAT YOUR ENTIRE RESPONSE IS NOT TO BE RELEASED!**

HAVE YOU PROPERLY ACKNOWLEDGED ALL AMENDMENTS? INSTRUCTIONS REGARDING HOW TO ACKNOWLEDGE AN AMENDMENT SHOULD APPEAR IN ALL AMENDMENTS ISSUED.

MAKE SURE YOUR BID INCLUDES A COPY OF THE SOLICITATION COVER PAGE. MAKE SURE THE COVER PAGE IS SIGNED BY A PERSON THAT IS AUTHORIZED TO CONTRACTUALLY BIND YOUR BUSINESS.

MAKE SURE YOUR BID INCLUDES THE NUMBER OF COPIES REQUESTED.

CHECK TO ENSURE YOUR BID INCLUDES EVERYTHING REQUESTED!

CHECK *AGAIN* TO ENSURE YOUR BID INCLUDES EVERYTHING REQUESTED!

IF YOU HAVE CONCERNS ABOUT THE SOLICITATION, DO NOT RAISE THOSE CONCERNS IN YOUR RESPONSE! **AFTER OPENING, IT IS TOO LATE! IF THIS SOLICITATION INCLUDES A PRE-BID CONFERENCE OR A QUESTION & ANSWER PERIOD, RAISE YOUR QUESTIONS AS A PART OF THAT PROCESS!** PLEASE SEE BIDDING INSTRUCTIONS AND ANY PROVISIONS REGARDING PRE-BID CONFERENCES.

This checklist is included only as a reminder to help bidders avoid common mistakes.  
Responsiveness will be evaluated against the solicitation, not against this checklist.  
You do not need to return this checklist with your response.

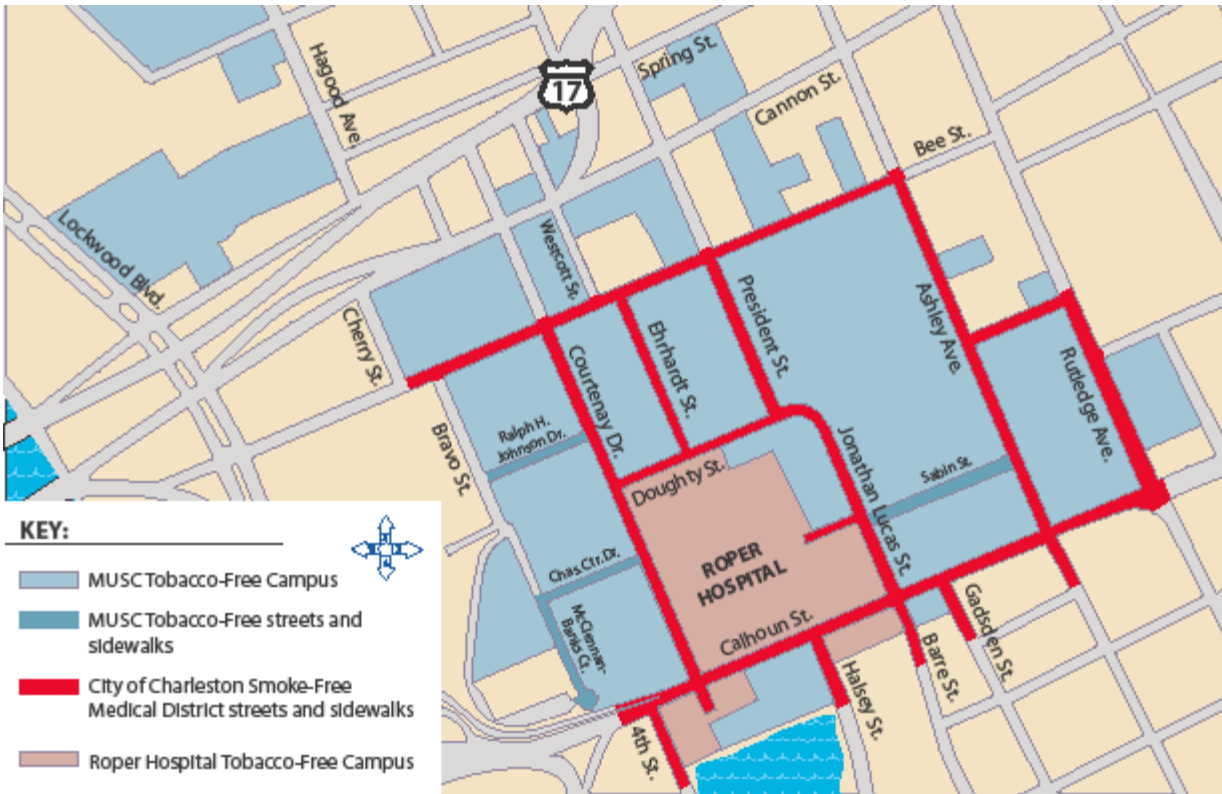

MUSC is a smoke free campus. This map identifies MUSC’s boundaries.

**Badges:**

Contractor shall be responsible for expenses incurred in having all personnel – contract and/or subcontract – working on the MUSC campus obtain MUSC Identification Badges. This includes a background check and possible Drug and TB Testing. Badges must be obtained prior to contract performance commencement.

**Smoking Policy:**

Acting upon the recommendations of the Student Government Association and the faculty senate, our board of trustees recently determined that MUSC has become a totally tobacco-free campus effective March 1, 2012.

As South Carolina’s academic health center and home to the only National Cancer Institute-designated cancer institute in the state, it is a part of our mission to prevent cancer and to lead by example in providing the healthiest environment possible for everyone on our campus.

Effective March 1, 2013, the use of tobacco products are prohibited on all streets and sidewalks within the Medical District as defined by the City of Charleston ordinance as well as all property owned or leased by MUSC. Amendments to the tobacco free campus policy also prohibit the use of tobacco products by staff on private properties adjacent to the Medical District without explicit approval from the property owner.

Other parking information can be found at: <http://www.muschealth.com/mapsparking/index.htm>

**THIS IS THE END OF THIS DOCUMENT**